

# HOW TO SPEAK RADAR



## BASIC FUNDAMENTALS AND APPLICATIONS OF RADAR

ARNOLD E. ACKER  
*CPI Electron Device Business*  
150 Sohier Road, Beverly, MA 01915-5536 USA

**For more information about our radar products  
Contact us at  
+1(978)922-6000  
[ElectronDevices@cpiedb.com](mailto:ElectronDevices@cpiedb.com)  
[www.cpi-edb.com](http://www.cpi-edb.com)**

**First Printing - October 1966  
Second Printing - May 1967  
Revised - January 1974  
Revised - August 1988**

# CONTENTS

Page No.

Uses of Radar .....	1
Desired Information . . . . , .....	1
Measurement information.....	1
Resolution of information .....	1
Ambiguous and unambiguous information .....	2
The Doppler Effect .....	4
Fourier transforms.....	5
The Radar Equation .....	5
Characteristics of target reflections .....	6
Probability of detection and false alarms .....	7
Clutter .....	7
Operating frequency.....	11
Types of radar by waveform. ....	12
Radar systems .....	12
CW Systems .....	12
CW Illuminators. ....	12
Velocity measuring radars.....	12
FM-CW Systems.....	13
Pulsed systems. ....	14
Elements of pulse modulation.....	14
Transmit-receive switching .....	16
Minimum range consideration .....	16
Receiver bandwidth .....	16
Pulse compression.....	19
Phase coherency.....	19
MTI, AMTI, Delay Line Canceller.....	20
Range-Gated MTI.....	21
Pulsed Doppler radar system .....	22
Monopulse radar system .....	22
Synthetic aperture radar system .....	24
Doppler beam sharpening .....	25
Bistatic radars.....	27
Over-the-Horizon radars.....	27
Missile RF guidance techniques .....	28
Antennas .....	30
Parabolic reflectors .....	30
Phased arrays. ....	30
Date rate. ....	31
Indicators.....	32
Radar ECCM.....	33
Low probability of intercept. ....	33
Microwave tubes used in radar systems .....	33
Radar systems bandwidth.....	35
Radar techniques .....	35
Future trends in radar .....	35
Radar relationships .....	36
Bibliography.....	37

## LIST OF FIGURES

Figure No.	Page No.
1. Velocity frequency measurement capability as a function of frequency of interruption (PRF ).....	2
2. Signal returns in range measurements.....	3
3. Information versus pulse recurrence frequency . . . . .	3
4. Curves of equal Doppler for an airborne radar.....	4
5. Comparative signal amplitudes and threshold level.....	7
6. A radar cell . . . . .	8
7. Stacked radar beams . . . . .	8
8. Sensitivity time control . . . . .	9
9. Airborne target/clutter Doppler returns . . . . .	10
10. Atmospheric attenuation due to water vapor . . . . .	11
11. Illuminator radar systems block diagrams . . . . .	12
12. Velocity measuring radar block diagram . . . . .	12
13. FM-CW range measuring radar block diagram . . . . .	13
14. Doppler effect on the difference frequency in an FM-CW radar . . . . .	13
15. Range and velocity measuring FM-CW radar block diagram . . . . .	14
16. Pulse modulation terms . . . . .	14
17. Pulsed radar frequency spectrum . . . . .	15
18. Pulsed radar system block diagram.....	15
19. Pulse compression radar block diagram.....	17
20. Pulse compression radar parameters . . . . .	17
21. Digital pulse compression - Barker 13 Code . . . . .	18
22. Coherent and non-coherent integration . . . . .	19
23. Coherent radar system block diagram . . . . .	20
24. Coherent-on-receive radar block diagram . . . . .	20
25. Delay line type of moving target indication.....	21
26. PRF switching for measuring range.....	22
27. Pulsed Doppler radar block diagram . . . . .	23
28. Monopulse radar antenna patterns . . . . .	23
29. Amplitude-comparison monopulse radar block diagram.....	23
30. Synthetic aperture antenna . . . . .	24
31. Doppler frequency history of a point target . . . . .	24
32. Recording of Doppler signal on raw data film. . . . .	24
33. Doppler signal modulation of signal film . . . . .	24
34. Synthetic aperture antenna radar signal film.....	25
35. Fresnel lens effect on focusing point targets . . . . .	25
36. Doppler beam sharpening.....	26
37. Bistatic radar . . . . .	28
38. Parabolic antennas . . . . .	30
39. Phased array antenna feed alternatives . . . . .	31
40. Various radar indicator presentations . . . . .	32

# Foreword

The following information is presented to give the reader a basic introduction to the subject of radar and to the application of radar equipment.

Historically, the basic principle of radar was demonstrated by Heinrich Hertz in 1888 and was later tested in Germany in the early 1900s. Nothing was really done to exploit the early demonstrations until the 1930s when a number of individuals, both in Europe and the United States, were concerned with the early detection of a bomber aircraft strike. Great Britain was first in deploying an operational radar system (the Chain Home in 1937) using available components of radio technology. The Chain Home radar operated at the now unseemly frequency of about 25 MHz. Most of the allied radars in the late '30s operated at frequencies from about 75 to 200 MHz, since that was the limit of the vacuum tube technology at that time. Perhaps the most significant development to advance radar technology occurred at the end of the decade in 1939, when the microwave cavity resonator magnetron was invented in England. This device then provided the radar industry with a very high power transmitting tube enabling radars to operate at microwave frequencies. At about the same time, the Varian brothers invented the klystron, first developing the reflex klystron for receiver local oscillator application.

The existence of the magnetron and the reflex klystron then made it possible to produce very effective radar systems in the early World War II timeframe.

The evolution of the radar art has grown steadily to the present level that employs sophisticated computerized techniques and has stimulated the development of increasingly complex components. These components have been needed to continually advance the art of gathering and applying better information in order to achieve new objectives. Many different kinds of radar equipment are manufactured that perform a variety of functions but they all have one common purpose: the extraction of information from a reflected radio signal. A radar equipment can simply be defined as an information machine. The kind of information and the resolution or accuracy of that information is a measure of the radar system and can vary appreciably according to what a radar system is intended to accomplish.

The word **radar** is an acronym coined from the expression "**Radio Detection And Ranging.**" As the following discussion will indicate, the original objectives of detection and ranging have grown to include radar imagery that approaches that of light photography.

# HOW TO SPEAK RADAR

## Uses of Radar

An equipment that uses the principles of radar is called a radar system. Such a system can be small enough to be installed in an automobile spotlight, such as a police speed-detection radar, or large enough to require one or more buildings to enclose a single radar system.

Some functions of radar systems are listed below together with an example of a typical radar system for each function.

---

Function	Example
1. Search	Early Warning Radar
2. Locate	Mortar Locator
3. Control	Air Traffic Control Radar
4. Navigate	Terrain Following Radar
5. Track	Target Tracking Radar
6. Map	Side-Looking Radar
7. Intercept	Attack Radar
8. Guide	Missile illuminator
9. Identify	Discrimination Radar
10. Measure	Velocimeter Radar
11. Warn	Threat Warning Radar
12. Dock	Capsule Docking Radar
13. Land	Microwave Landing System

---

## Desired Information

In performing the above functions, the radar systems must obtain certain information from the radar signal. The kinds of radar information that can be extracted include:

1. Range
2. Range rate or velocity
3. Acceleration
4. Azimuth (angular) direction
5. Elevation angle
6. Target size
7. Target shape
8. Change in target shape
9. Particular target identification or "target signature" (such as spin rate)

## Measurement Information

The extraction of information from the returned echoes of a radar transmitter is performed by analyzing the returned signals in terms of (1) the time of arrival of signals and (2) the detected

the signal. In the first instance, measurements are made in the **time domain**. By knowing that the velocity of propagation of a radiated signal is equal to the velocity of light and by measuring the time elapsed between transmission and reception, the distance that the signal traveled can be determined and displayed. Thus, **range** measurement is made in the time domain. (Distance = Time x Velocity.) A radar signal will travel to a target one mile away and return in about 10 microseconds.

When a signal is reflected from a target

moving in a relative radial direction, an effective shift in frequency is experienced. This frequency shift is known to be caused by the Doppler Effect, and the magnitude of the frequency shift is measured by determining the frequency difference between the transmitted frequency and the frequency of the returned signal. This measurement is made in the **frequency domain** and is the means of determining the relative radial velocity of a moving target in relation to the position of the radar. In a very complex radar system, measurements may be made in both time and frequency domains in order to extract as much available information from the returned signal as can be obtained within the present art.

frequency changes or phase changes of

## Resolution of Information

The degree of resolution of radar information is defined as how well a radar system can separate two signals that are close to each other either in terms of time measurement (range) or frequency measurement (velocity). Obtainable resolution depends upon (1) the amount of information transmitted (bandwidth and modulation), (2) the manner in which the transmitted signal is directed and received (antenna directiveness), and (3) the manner in which the returned signal is detected and processed.

**Range resolution** is obtained by using either (1) very short transmitted pulses so that targets that are close together can be detected at different times, (as a radar pulse may be long enough to dwell on two closely spaced targets simultaneously), or by (2) employing modulation to the pulse to enable discrimination between two signals that are received simultaneously. This is described later in the section on Pulse compression.

**Angular** (azimuth or elevation) **resolution** depends upon the beamwidth of the antenna. Angular resolution decreases as the range increases, since the antenna beam becomes wider with increased range. The obvious way to improve angular resolution is to employ a very directional antenna beam that is as narrow as can be achieved. A second method is to apply advanced Doppler sensing techniques as is described later in the discussions on Synthetic Aperture Radar Systems and Doppler Beam Sharpening.

**Velocity resolution** depends upon the ability of the receiver and the detector to discriminate in frequency. Velocity measurements are achieved with a group of Doppler filters and the discrimination between adjacent Doppler frequencies is then determined by the frequency bandwidth and selectivity of each Doppler filter.

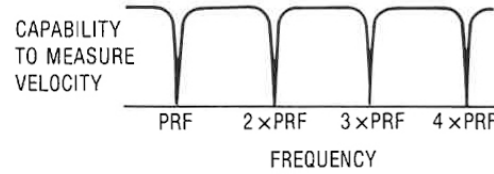
Generally, the factors that increase resolution can be summarized as follows:

Angular Resolution	Range Resolution	Velocity Resolution
1. Narrow Antenna Beamwidth	1. Short Pulsewidth	1. Narrow Doppler Frequency Filter Bandwidth
2. Doppler Sensing	2. Pulse Compression	2. Digital Doppler Processing

### Ambiguous and Unambiguous Information

The words "ambiguous" and "unambiguous" are used frequently in radar system design considerations when speaking of extracting information when either (1) more than one signal is available for the correct information, making the correct value uncertain, or (2) there are conditions that do not allow the correct information to be extracted. If a measurement can be made in a continuous manner, the measurement is an unambiguous one. For example, if velocity is measured by measuring the Doppler frequency shift of a continuous wave (CW) transmission, the measurement is a continuous one and there is no extraneous velocity information that will confuse the measurement. However, if the CW transmission is interrupted at some periodic rate, the velocity information in terms of a frequency measurement relative to the carrier frequency becomes confused with the sidebands produced by the frequency of

interruption. Further, the velocity information that corresponds to the frequency of interruption and its multiples cannot be measured. The capability to measure Doppler frequencies relative to pulse recurrence frequency is shown in **Figure 1**.



**Figure 1.** Velocity frequency measurement capability as a function of frequency of interruption (PRF).

In the case of range measurement, if only one pulse is transmitted, all ranges can be measured with no ambiguity. However, as soon as a second pulse is transmitted, unambiguous range measurements have the limit of the interpulse time before becoming ambiguous.

If a reflected signal appears at the same time as the next pulse is transmitted, the signal is not able to be detected and is said to be "eclipsed." If a reflected signal appears after the next pulse is transmitted, the signal is received as an ambiguous signal and is referred to as a "second time around" target. **Figure 2** diagrams the time relationship of various return signals in range measurements.

A comparison of measurements in both the time and frequency domains is illustrated in **Figure 3**. In advanced radars many modes of operation are required such as search, intercept, mapping, etc. Each mode has particular kinds of information that are desired and in order to obtain optimum information for a particular mode of operation, a change in the pulse recurrence frequency (PRF) is usually necessary. For example, in airborne radar, a low PRF operation will have the principal advantage of the ability to sort clutter from targets on the basis of range as clutter does not consume the entire unambiguous range interval. A low PRF system also is free of spurious signals called "ghosts" since the range is unambiguous and no range correlation is required. However, in the frequency domain the low PRF velocity information is ambiguous and can be blind at the velocities corresponding to each PRF line. Looking at the same parameters that correspond with the high

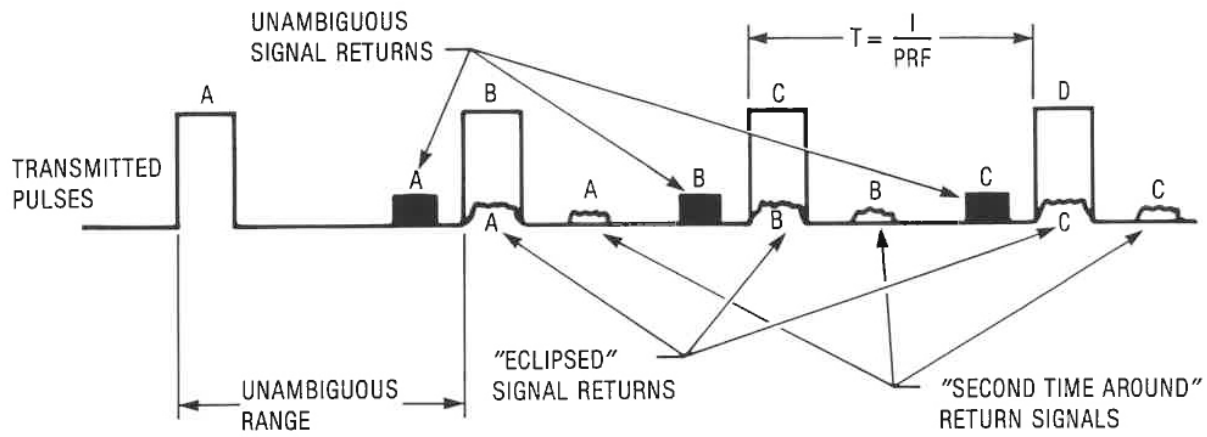


Figure 2. Signal returns in range measurements.

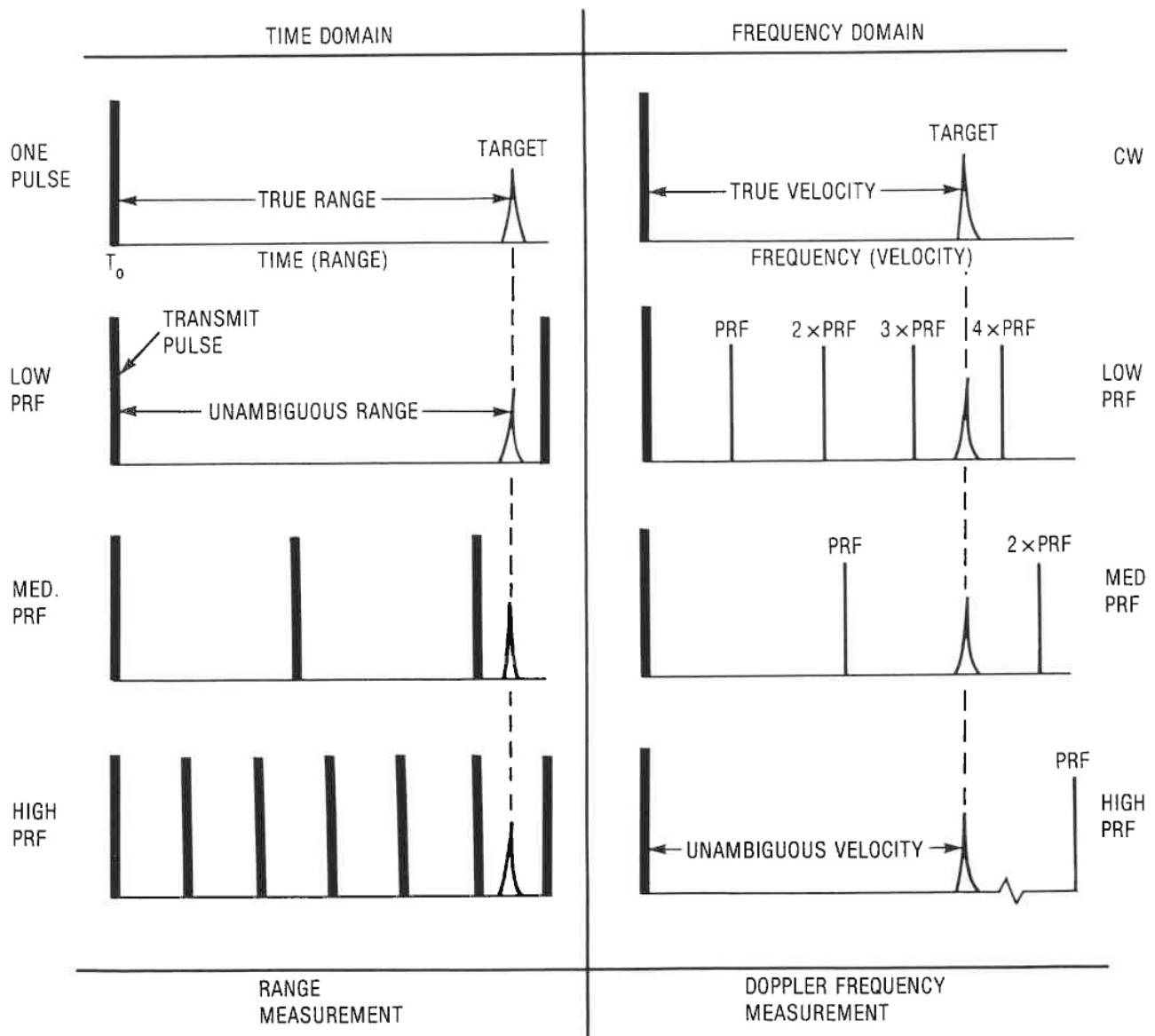


Figure 3. Information versus Pulse Recurrence Frequency.

PRF system, the measurement of frequency becomes unambiguous as there is significant Doppler frequency bandwidth between the PRF lines. For this reason, the PRF is commonly made more than the maximum expected Doppler frequency. The range measurement with a high PRF then becomes one of an ambiguous character and correlation techniques involving PRF switching are necessary to measure range. The above considerations and various compromises in each are taken into account in the design of the various waveforms that a radar system will use.

### The Doppler Effect

The Doppler Effect is that effect which gives an apparent change in frequency if either the source of radiating energy or the reflecting target is in radial motion relative to the other. The Doppler frequency shift is a function of the relative radial velocity and the oscillating frequency and their relationship is shown in the formula:

$$F_d = \frac{2V_r}{\lambda} = \frac{2V_r F_o}{c}$$

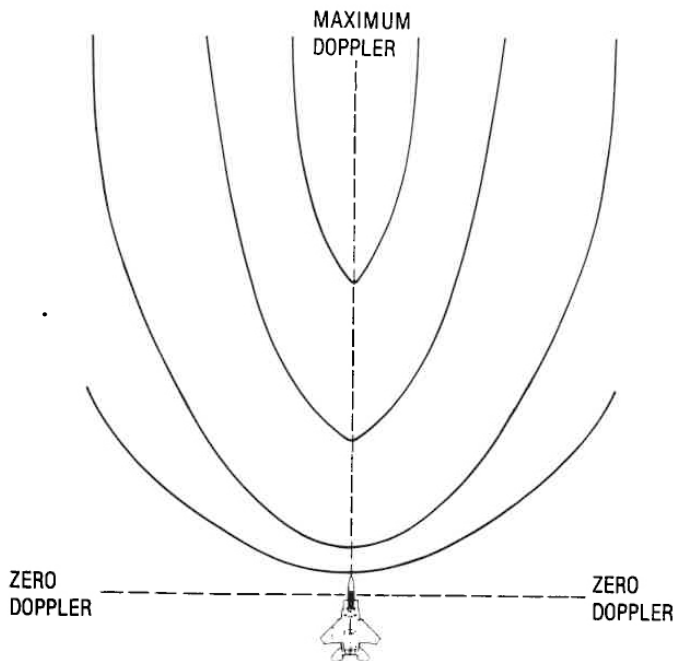


Figure 4. Curves of equal Doppler for an airborne radar.

where:

$F_d$  = Doppler Frequency Shift

$V_r$  = Relative Velocity

$\lambda$  = Wavelength

$F_o$  = Transmitted Frequency

$c$  = Velocity of Propagation

From the above equation, we learn that a radial velocity of one nautical mph provides a Doppler frequency shift of about 34 Hz at an operating frequency of 10 GHz.

Note that the **relative** radial velocity parameter is important in measuring Doppler frequency shift, since a vehicle moving at a high velocity in a circle about a fixed radiating source does not create a Doppler frequency shift, as the distance between the two objects does not change. Further, if the vehicle and the radar are moving in a straight line at the same velocity and in the same direction there is also a zero Doppler effect between the two as there is no change in range.

Figure 4 illustrates the Doppler shift of surface targets that an airplane would measure when looking forward at different angles from bore-sight. The plots of equal Doppler frequency shifts ("isodops") come about from the angle that the antenna beam scans off of boresight together with the angle relative to the ground plane.



The measurement of the Doppler Effect then becomes an important identifier of a target and can be used for measuring parameters such as target velocity, target acceleration and spin rate. As will be discussed in the discussions of synthetic aperture antenna and Doppler beam sharpening techniques, the measurement of Doppler frequencies is also used as a means of improving the azimuth resolution of a radar system.

## Fourier Transforms

As mentioned, radar measurements are made in both time and frequency domains. A radar signal can be represented in either domain, and being able to translate the representation from one domain to the other is very useful in modern signal processing. The mathematical expression for transforming from the time domain to the frequency domain is called the **Fourier Transform**. For example, range signals in FM-CW radar are perceived in the frequency domain and may be transformed into time domain signals (Inverse Fourier Transform) for presentation on a display that shows signals in a time-based format. These transformations are now possible with modern digital devices and techniques. It is also done with optical processors as is the case with synthetic aperture radar data processing.

## The Radar Equation

A radar system uses the phenomenon of a body reflecting (repropagating) high-frequency electromagnetic energy, to obtain an "echo" return to a high frequency transmission. The manner in which a wave of energy is transmitted (the waveform) and received is a choice that is always fitted to the intended use of a radar equipment. Generally, one particular measurement is desired most, such as range, so that other information (velocity, elevation, etc.) may be compromised, if necessary, as a less important objective.

The detection performance of any radar depends upon many factors that are related in what is traditionally known as the Radar Equation. There are a number of forms of this equation. One common form equates the ratio of the returned signal power,  $S$ , to the receiver noise power,  $N$ , as shown in the following:

$$\frac{S}{N} = \frac{PG^2\lambda^2\sigma}{(4\pi)^3R^4\overline{NF} kTB L}$$

Where:

- P = Transmitted power
- G = Antenna gain
- A = Wavelength
- $\Sigma$  = Target cross section
- R = Range of target
- $\overline{NF}$  = Noise figure of receiver
- k = Boltzman's Constant
- T = Temperature
- B = Bandwidth
- L = Assorted losses

The radar equation is derived in the following steps:

1. The power **density** at a target of range R is equal to the peak power radiated from a transmitter divided by the area of a sphere of radius R.

$$P_d = \frac{P}{4\pi R^2}$$

2. If the signal is directed by an antenna with gain, G, then

$$P_d = \frac{PG}{4\pi R^2}$$

3. The reflected power density from the target will be a function of the target cross section,  $\sigma$ . The reflected power from the target is:

$$P_r = \frac{PG\sigma}{4\pi R^2}$$

4. The power **density** of the reflected signal at the radar is:

$$P_d = \frac{PG\sigma}{(4\pi R^2)^2}$$

5. The power of the reflected signal, S, at the radar is the product of the power density times the area of the antenna. (A = aperture)

$$S = \frac{PG\sigma A}{(4\pi R^2)^2}$$

6. Substituting the relationship of gain and aperture,

$$A = \frac{G\lambda^2}{4\pi}, \text{ then } S = \frac{PG^2\lambda^2\sigma}{(4\pi)^3R^4}$$

7. When equating as S/N, the noise figure of the receiver, NF, and the thermal noise power, kTB, become part of the denominator.

$$\frac{S}{N} = \frac{PG^2\lambda^2\sigma}{(4\pi)^3R^4\overline{NF} kTB}$$

8. The term L, representing a number of losses in the radar system and propagation losses, is introduced accordingly, making the equation:

$$\frac{S}{N} = \frac{PG^2\lambda^2\sigma}{(4\pi)^3R^4NF kTB L}$$

In a pulsed radar that operates with low pulse recurrence frequencies, typically less than 3 kHz, most of the returned energy will be utilized in detecting the received signal. If the frequency spectrum as shown in **Figure 17** is about 2 MHz wide, at the null points, a receiver with a bandwidth of a few megahertz will accept most of the energy in the returned signal. For this reason, when using the radar equation for low PRF pulsed radars, the peak value of transmitted output power times the duty cycle (PRF x pulsewidth) is used.

In pulsed radars that operate at high pulse recurrence frequencies from 10 kHz to 500 kHz (pulsed Doppler types), the usable returned energy is that of one spectral line, since the principal measurement of interest is a frequency domain measurement and the frequency (Doppler) information is common to each spectral line. Hence, only a portion of the returned energy is utilized and the power term in the radar equation becomes the peak transmitted power times the square of the duty cycle.

If  $R_0$  is designated as the range that provides unity S/N, then the equation becomes:

$$R_0^4 = \frac{PG^2\lambda^2\sigma}{(4\pi)^3NF kTB L}$$

When this range is known, then the S/N at other ranges can be calculated by using the relationship:

$$\frac{S}{N} = \left(\frac{R_0}{R}\right)^4$$

Significantly, the S/N is inversely proportional to the fourth power of range.

Knowing the above relationships, one can calculate the parameters for specified ranges that provide useful return signals.

## Characteristics of Target Reflections

A particular target, an airplane for example, is made up of many surfaces and "point scatterers" that reflect the radar signal. The strength of the reflected signal is dependent upon the reflectivity and directivity of the target. Reflectivity is defined as the fraction of the intercepted signal power that is re-radiated. Directivity is defined as the ratio of power reflected to the radar compared to the power radiated from the target in all directions.

The combined return signal will be made up of reflections from different parts of the target and these reflections may either combine favorably or even cancel if the return path lengths are such that the differences in signal phase at the receiver are close to 180°. At 10 GHz the wavelength is only 3 cm so the possibility of fluctuations in signal strength is quite probable. This is referred to as target scintillation. There are a number of techniques to reduce target scintillation, including changing the frequency of the transmitted signal (frequency agility) and changing the polarization of the transmitted signal (polarization agility).

An important factor in the radar equation is that of Radar Cross Section (RCS). This describes the relative size of the target and is best visualized as the geometric cross-section of the target factored by the reflectivity and directivity of the target. To define radar performance the radar cross section is commonly specified in terms of a particular size of sphere, such as a sphere having 1 square meter of surface. An unfriendly target can reduce its radar cross section by geometric design that reduces directivity and by the use of absorptive materials that reduce reflectivity.

Targets with moving parts, such as turbine blades or tank treads, may reflect radar signals that can identify themselves to a certain degree. For example, a tank tread moves twice as *fast* as the tank it propels, so a radar that measures the Doppler frequencies in the target return from a tank will see two distinct frequencies, one twice the other.

Unfortunately, the radar cross section of a target varies considerably with the angle of reflection, making it difficult to use its "radar signature" as a reliable means of target identification. However, current advances in processing Doppler signals are improving the probabilities of target identification by increasing the capabilities of creating real time radar images.

## Probability of Detection and False Alarms

A radar receiver has a means of setting the "threshold level"; a level a return signal must exceed to be seen on an indicator or to be used in some other manner. Unfortunately, noise signals are not at one constant level and can vary as illustrated in **Figure 5**. If a threshold level is set high enough to prevent any noise signals from appearing, the radar's sensitivity is reduced considerably. If the threshold is set too low, then too many false indications may be seen, and the noise signals will tend to complicate detection of the desired information. Therefore, a compromise level is selected by adjusting manually or automatically for specific operating conditions. The threshold level can then set the "false-alarm rate" of the radar, which is simply the number of false-alarm signals that appear in a given time period, such as one minute.

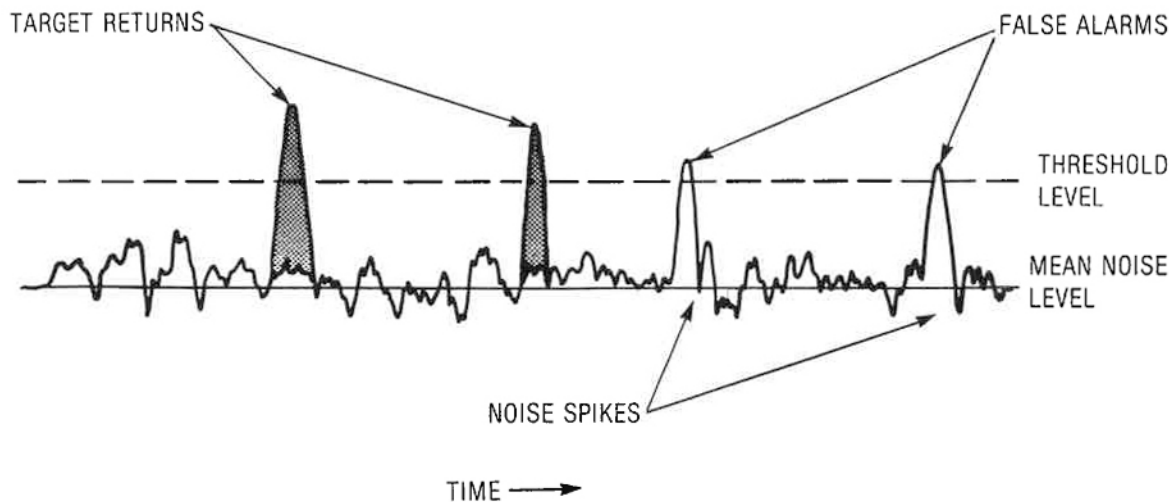
The probability of target detection depends on many variables, including propagation loss, the relationship between the signal-to-noise ratio,  $S/N$ , and the threshold setting in the detection circuitry. In the case of a moving antenna, it also is dependent upon such factors as antenna scan rate, antenna beamwidth, and the pulse recurrence frequency, all of which determine the "look time":

Obviously, the probability of target detection is increased with a more powerful transmitted signal, more antenna directivity, and longer transmission time on the target, together with a more sensitive receiver with a long "listen" time and an efficient detector. Unfortunately, all of these dependent factors cannot always be applied simultaneously, and performance compromises are often tolerated.

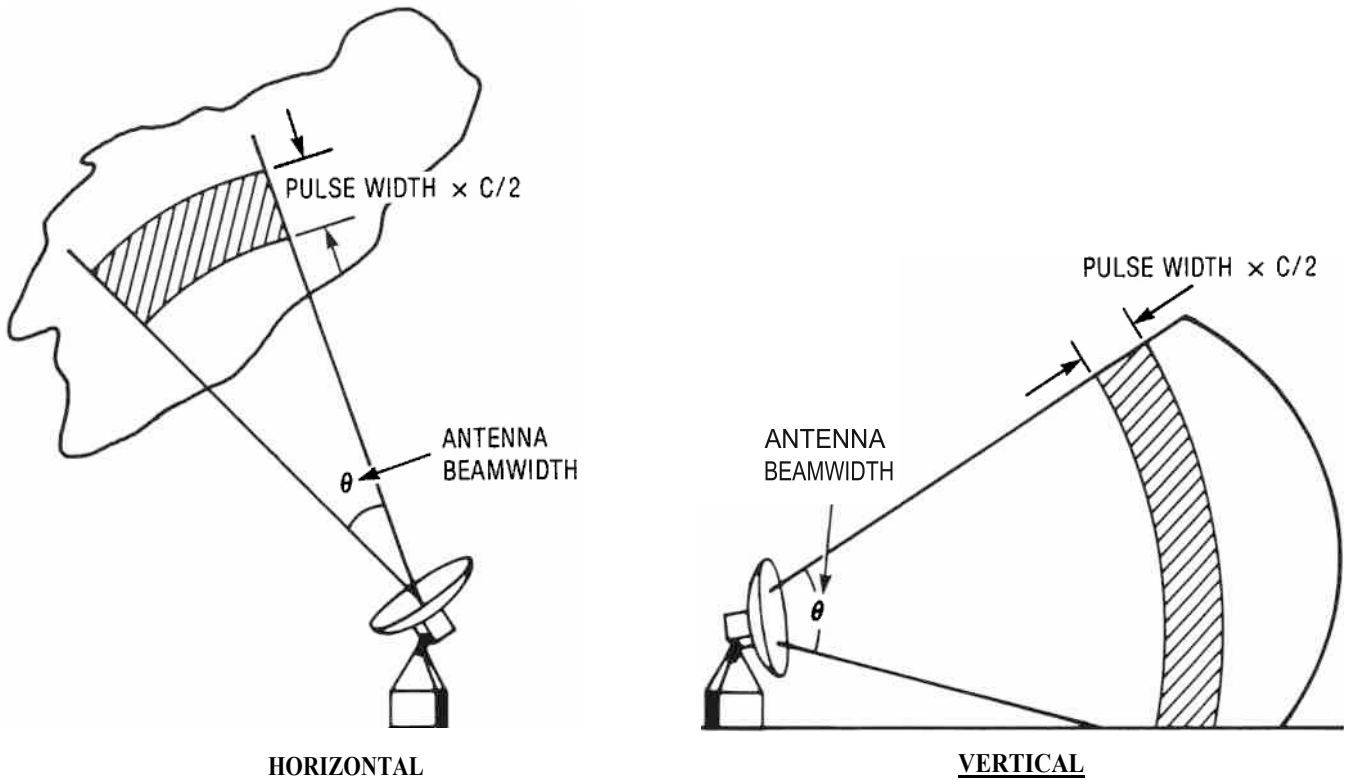
## Clutter

Clutter, the bane of radar designers, is to radar what static is to radio. Although there are some specialized radars that are made to detect meteorological phenomena such as clouds, rainfall, wind shear, etc., most radars are designed to detect man-made objects such as tanks, ships, aircraft, etc. These man-made objects are detected to the exclusion of radar echoes from the ground, sea or weather phenomena. These unwanted echoes are usually spoken of together under the category of "clutter".

Clutter energy is proportional to the size of the radar cell. In the horizontal plane, the radar cell is the instantaneous area of illumination by a radar pulse of the target area, at a given range, as if the radar's antenna beam was stationary. (See **Figure 6**.)



**Figure 5.** Comparative signal amplitudes and threshold level.



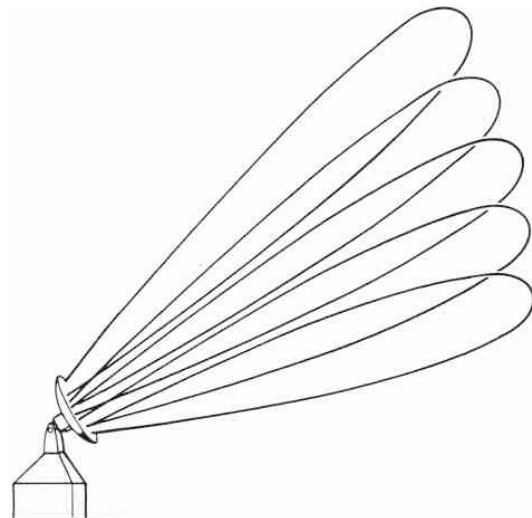
**Figure 6.** A radar cell.

The area of the cell is dimensioned by the antenna beamwidth, the pulse length and the angle of incidence. Reducing the antenna beamwidth or the pulse length will then reduce the size of the radar cell and the level of clutter. There are limits to doing that since the beamwidth of an antenna is a function of the antenna size while the pulse length affects the radiated pulse energy, an important parameter in target detection in terms of average power on the target. A third dimension in the radar cell is in the vertical plane and thus the vertical beamwidth is also a matter of concern. In this case, clutter is increased to the benefit of vertical radar coverage. Vertical coverage is sometimes improved by using a number of stacked beams (see **Figure 7**) in the vertical plane to increase the clutter performance as well as to add an altitude dimension to the radar. Fast vertically scanned narrow beams also are used to accomplish the same objective.

As radar measurements are obtained in time and frequency domains, methods for improving target-to-clutter performance are applied in both domains. The basic objective in designing clutter rejection in a radar is to be able to see the target in clutter and not merely to eliminate the clutter. If a radar can adjust the system's receiver gain so that

the level of clutter is reduced to that of normal background noise, then any target larger than the clutter will be detectable. However, using this scheme only permits the detection of targets above the clutter level and the system will have no sub-clutter visibility, i.e., the capability of seeing targets in clutter.

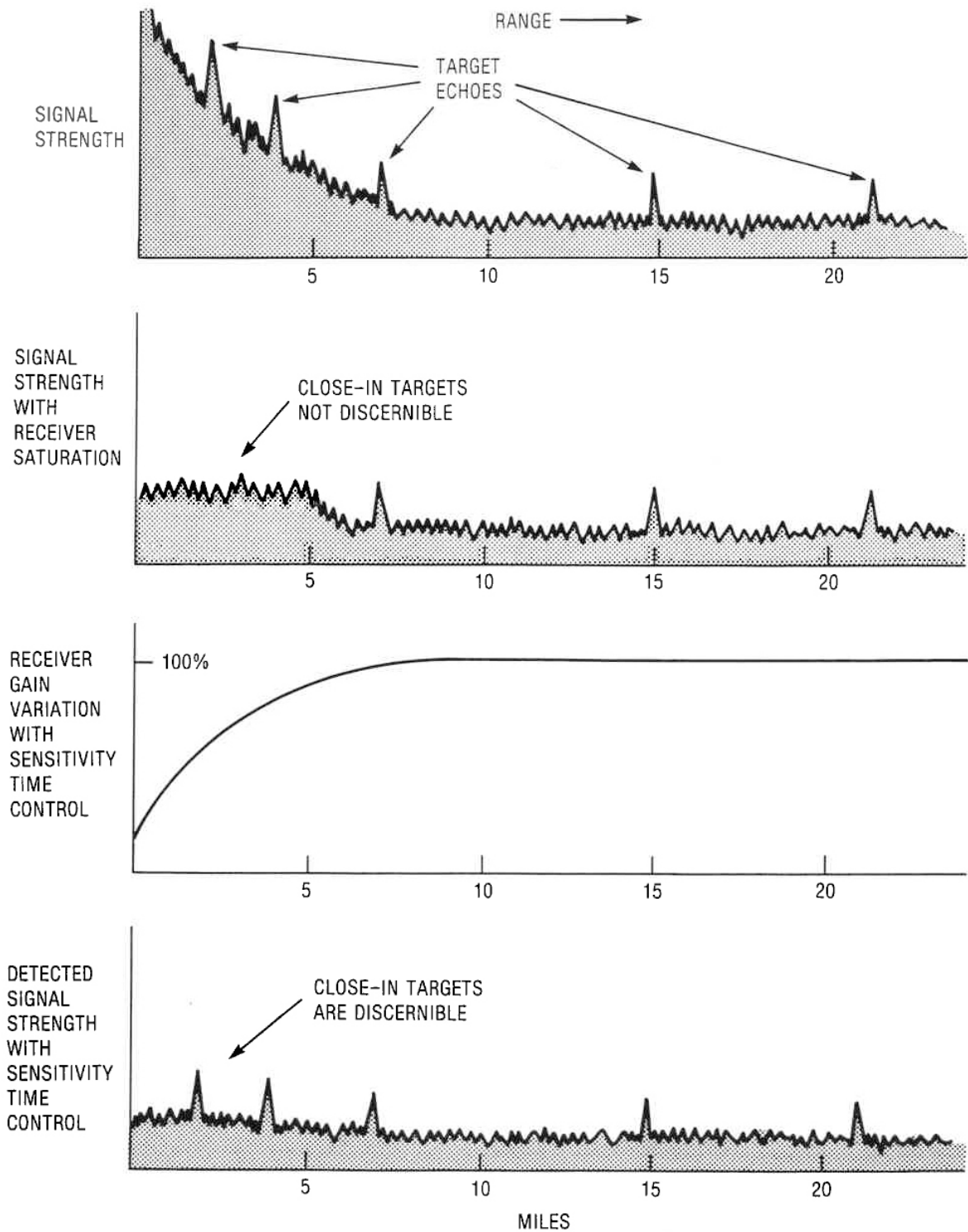
One means of improving clutter performance is to use an automatic receiver bias circuit called STC, Sensitivity Time Control. STC is a means of



**Figure 7.** Stacked radar beams.

varying the bias (gain) on the radar receiver so the sensitivity is reduced at close ranges and increases with longer ranges. (See **Figure 8.**) This is also effective in reducing false alarm targets that are caused by smaller targets such as birds, etc. Another technique to reduce clutter by using

time domain methods is to have a means of canceling out targets that are essentially fixed by storing them in some manner from pulse to pulse and canceling them against themselves, therefore making the radar essentially one that sees only moving targets. This is described later under the discussion of MTI radars.



**Figure 8.** Sensitivity Time Control.

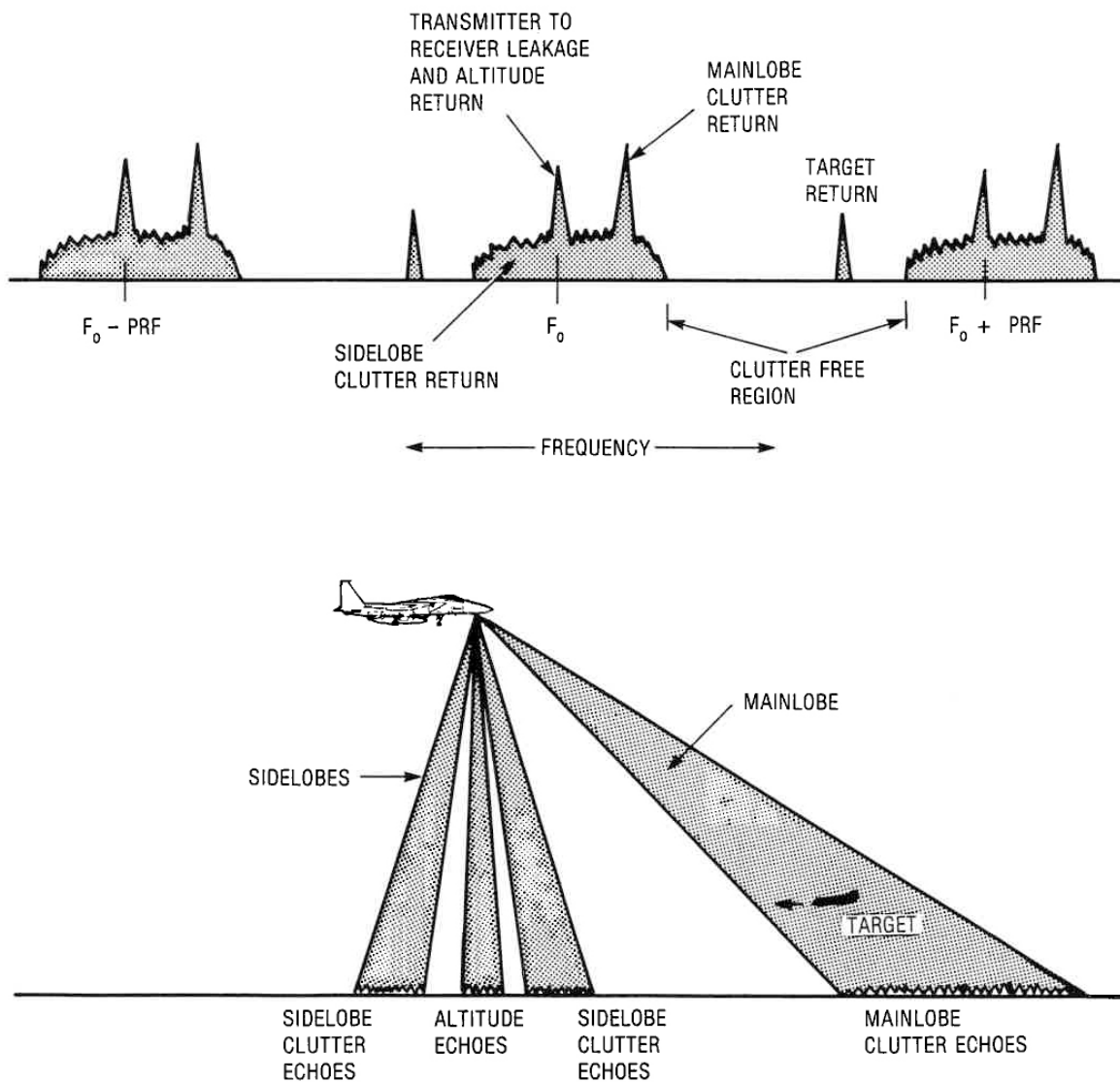
In order to detect Doppler frequency, the radar compares the target return with the phase of the transmitted pulse. Fixed targets will not cause a Doppler frequency shift and in a radar that is sensitive only to Doppler-shifted targets, the fixed targets are then essentially eliminated. Unfortunately, clutter in the frequency domain can occur due to moving leaves, trees, ocean waves, clouds, birds, etc. If the transmitter can be made to be very stable in phase, then real targets can be detected in a high clutter environment as clutter returns lack the periodicity of man-made targets returns, and with appropriate frequency filtering, the ability to see targets in clutter can be achieved.

If the radar itself is moving, such as an airborne

radar, then the fixed targets on the ground also have Doppler shift to them (see **Figure 4**) which will give rise to clutter in the frequency domain not only from the reflections from the main beam of the antenna but also from the side lobes of the antenna.

**Figure 9** illustrates how clutter in an airborne system is dependent on the velocity of the radar platform. To provide a clutter-free Doppler region for detection of high-speed targets, a high pulse recurrence frequency is used in order to spread the sidebands in the transmitted spectrum.

In any case, where one is trying to improve the target-to-clutter ratio it is very important to have the stability of the transmitter as good as is possible



**Figure 9.** Airborne target/clutter Doppler returns.

as any particular variation in transmitter signal stability will adversely affect the target-to-clutter ratio. In addition, such other instabilities as time jitter, amplitude jitter, etc., will reduce the effectiveness of clutter reduction circuitry.

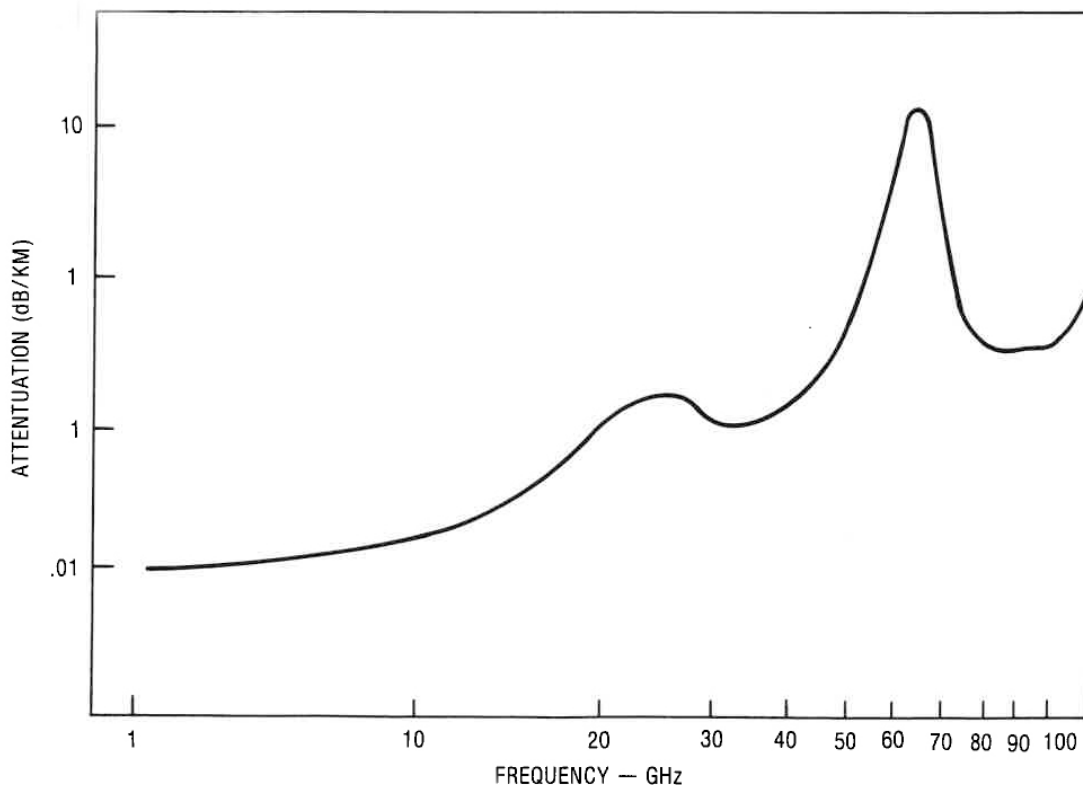
The sub-clutter visibility factor is defined as the ratio, at the input to the system, of the clutter energy to the signal energy of a target when it is just detectable at the output in the clutter residue. This is sometimes difficult to define and due to the fact that the sub-clutter visibility ratio does not take into account the overall performance at all target speeds, sometimes a preferred figure of merit is the target improvement factor. This is defined as the improvement in target-to-clutter ratio averaged over all target speeds.

There are various figures of merit for radars as far as clutter reduction is concerned. A typical number for a two-pulse canceller MTI (Moving Target Indication) radar is 30 dB where a three pulse canceller MTI radar can be as good as 40 dB. These figures can be compared with a pulse Doppler system where the sub-clutter visibility can be of the order of 50 to 60 dB. It should be noted that there are radar equipments, which can operate very acceptably with only 30 dB sub-clutter visibility,

dependent upon the particular application and objectives.

### Operating Frequency

The operating frequency of a radar is chosen to best achieve given objectives. Angular resolution can be improved by transmitting at high frequencies, since antenna beamwidth can be made smaller. Higher operating frequencies allow smaller antennas, more compact equipment packaging, etc., but compromise power handling capability and experience higher propagation attenuation losses. In some applications, where only short ranges are required, such as in an airport surveillance radar or a low-level tracking radar, higher operating frequencies are ideal for achieving optimum angular resolution. A radar frequency may be intentionally chosen at a frequency high in propagating attenuation for secure, short range operational reasons. Extremely long-range radars will use lower operating frequencies to take advantage of the various propagation phenomena such as refraction effects and lower propagation attenuation. **Figure 10** plots propagation attenuation loss due to water vapor as a function of operating frequency.



**Figure 10.** Atmospheric attenuation due to water vapor.

## Types of Radars by Waveform

To obtain various kinds of information, different techniques must be used to optimize the kind of information that is desired. Thus, radar systems fall into the following categories according to the "waveform" or mode of operation that is employed in a radar system. The general categories are:

1. CW (Continuous Wave)
2. FM-CW (Frequency Modulated, Continuous Wave)
3. Pulsed
4. Pulsed Doppler

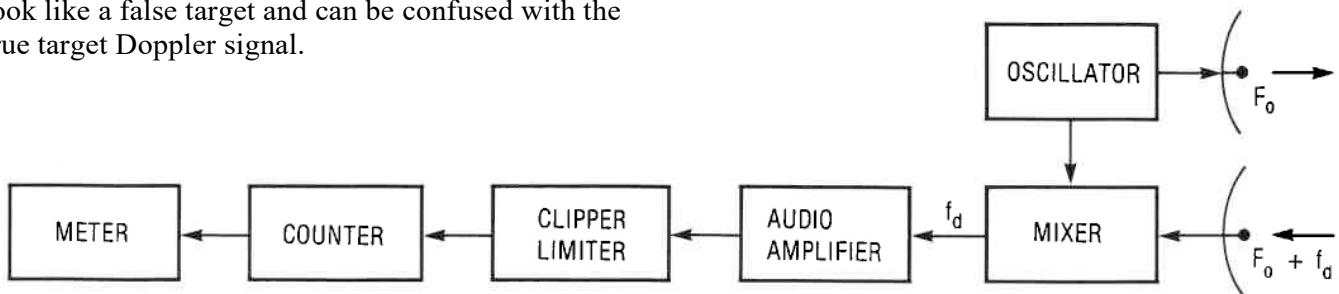
## Radar Systems

### CW Systems

A CW radar utilizes the Doppler Effect for measurement and is used primarily where unambiguous velocity information is desired. CW radars are usually single target devices and are used principally for (1) CW missile guidance systems (the transmitters are called CW illuminators, since they illuminate the target with energy), (2) velocity measuring radars, including police radars and instrumentation radars, (3) personnel detection radars, and (4) rate-of-climb meters.

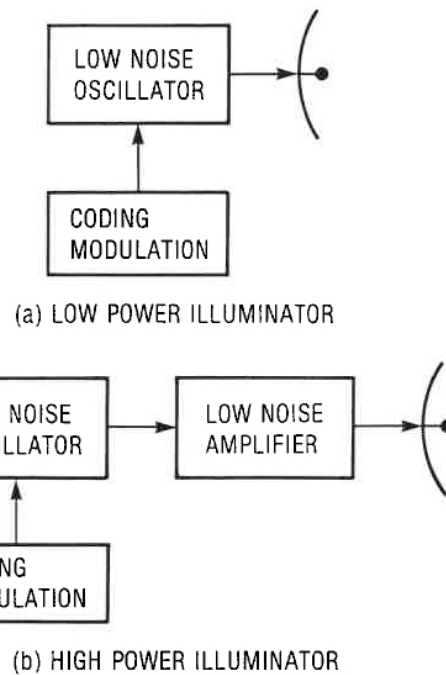
### CW Illuminators

This kind of radar transmitter is characterized by its low noise requirements. In a CW guidance mode of operation, a missile is guided by information derived from the Doppler frequency shift in the reflected signal from the target, due to the relative velocities of the target and the missile. Since Doppler frequency shifts are usually less than 100 kHz, it is extremely important to transmit a "clean" Doppler signal spectrum, otherwise a spurious Doppler signal may look like a false target and can be confused with the true target Doppler signal.



**Figure 12.** Velocity measuring radar block diagram.

A coded modulation capability is generally included in an illuminator to transmit information to the missile from the ground. Typical block diagrams are shown in **Figure 11**.



**Figure 11.** illuminator radar systems block diagrams.

### Velocity Measuring Radars

A typical block diagram of a velocity-measuring radar is shown in **Figure 12**. In the case of a police radar or a "speed-gun"; the transmitting signal doubles as the local oscillator signal to provide a difference frequency that is dependent upon the velocity of the automobile. The difference frequency is simply measured and used to provide an indication on a meter.

Personnel detection CW radars perform much like police radars except that headphones can be



used to detect the Doppler frequencies instead of a meter, as the Doppler frequencies will be audible.

Rate-of-climb radars operate similarly, except that they detect the phase relationship of a receding or approaching target by employing two receiver channels and local oscillator signals in quadrature. Transmitted power is generally less than one watt for police, personnel, and rate-of-climb types of radars.

CW radars are smaller than corresponding pulsed radars, although two antennas are required, and can operate against targets to almost zero range. CW systems can be somewhat power limited, since transmitter noise due to coupling between the antennas will affect receiver sensitivity.

### FM-CW Systems

A CW radar to measure both range and velocity of a target is accomplished by broadening the transmitted frequency spectrum by frequency modulating the carrier frequency. Range, in terms of frequency, can be determined by measuring the difference between

the received and transmitted frequencies as shown in **Figure 13**. The modulation can also be linear in one direction only, as in a "sawtooth" waveform.

When only range information is desired and the target is stationary, such as in an altimeter application, the modulation need not be linear, as shown in **Figure 13**, but can be sinusoidal or near sinusoidal, since only an average difference frequency measurement is required to yield an acceptable value of range. If the target is moving, the returned signal will include a Doppler shift in frequency. This information can be used to advantage in a Doppler Navigation Radar where both altitude (range) and velocity (Doppler shift) information are desired. When Doppler frequency shift information is desired, linear modulation is needed to provide an accurate measurement of Doppler frequency shift. **Figure 14** illustrates the frequency differences in an example where the returned signal frequency is affected by a positive Doppler frequency.

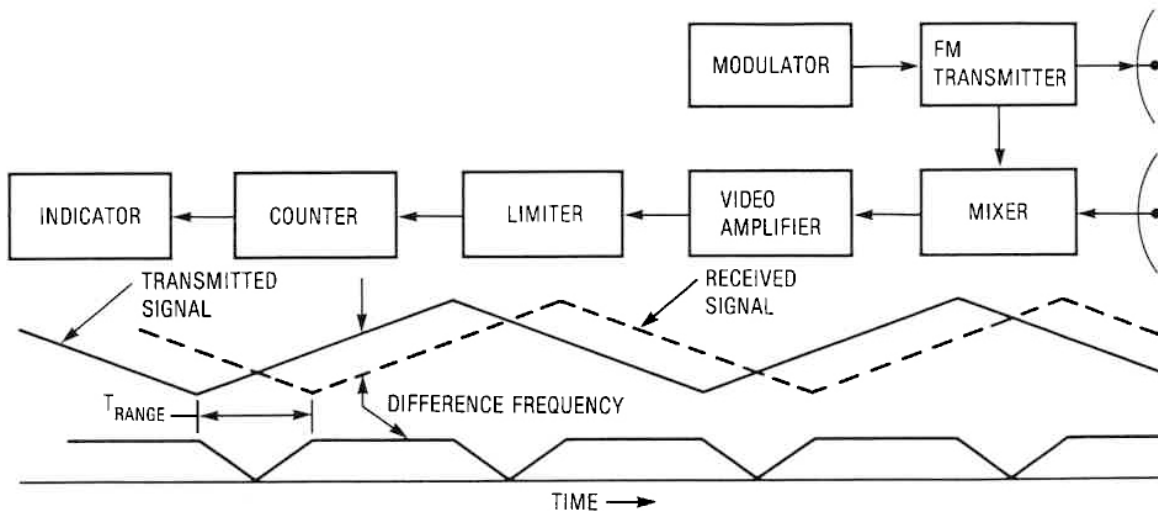


Figure 13. FM-CW range measuring radar block diagram.

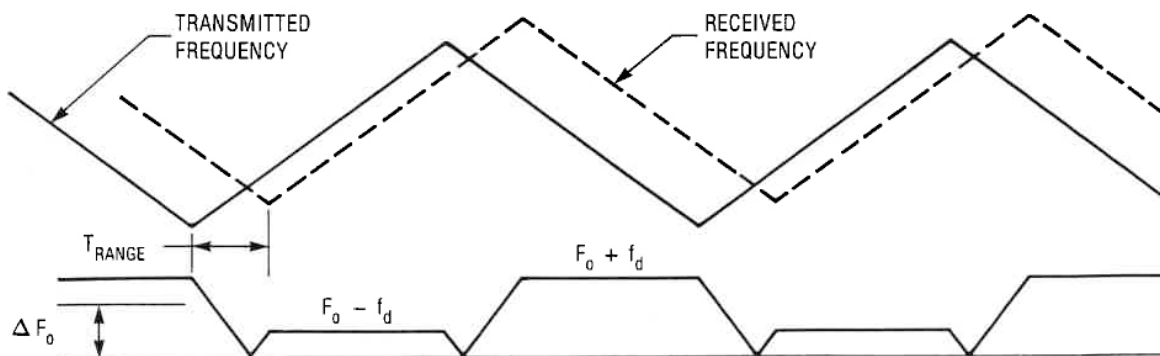


Figure 14. Doppler effect on the difference frequency in an FM-CW radar.

The positive Doppler frequency shift will have an effect on the received difference frequency, and a lesser total frequency shift will be observed if the frequency modulation is in an increasing frequency direction. When the modulation is in a decreasing frequency direction, the positive Doppler Effect will increase the total frequency shift. If a means is provided to measure each difference frequency,  $F_0 + f_d$  and  $F_0 - f_d$ , then the difference between the two frequencies is twice the Doppler shift and can be used accordingly to measure velocity. **Figure 15** is a simplified block diagram of an FM-CW radar that can extract the average frequency difference (range) as well as the Doppler frequency shift (velocity).

FM-CW radar systems have long been used as single target systems as it has been difficult to separate targets on the basis of frequency discrimination and display them in a time referenced manner. Recent radar developments are taking advantage of the advancements in digital signal processing and FFT (Fast Fourier Transforms) technology to demonstrate a practical short-range navigation radar with acceptable range resolution. A real advantage in this type of radar is the ability to operate at very low power levels (a few watts), requiring a relatively simple transmitter. With low power output the LPI (Low Probability of Interception) of the radar can become attractive militarily.

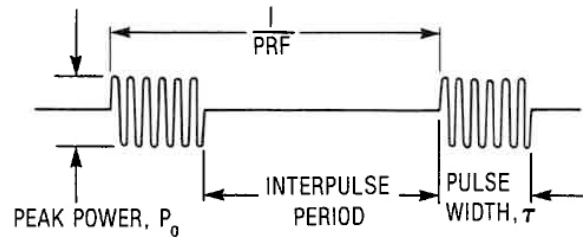
A disadvantage of the FM-CW radar is in the need for two antennas, a transmitting and a receiving antenna, adding to system size and weight.

Another method of obtaining range information in a CW radar is by expanding the transmitted spectrum to more than one transmitted frequency. If two signals are transmitted, the phase relationship between the two signals will vary as a function of range, and radars can be designed to measure range by providing an accurate phase-measuring capability. The two-frequency type of radar is adaptable to surveying applications.

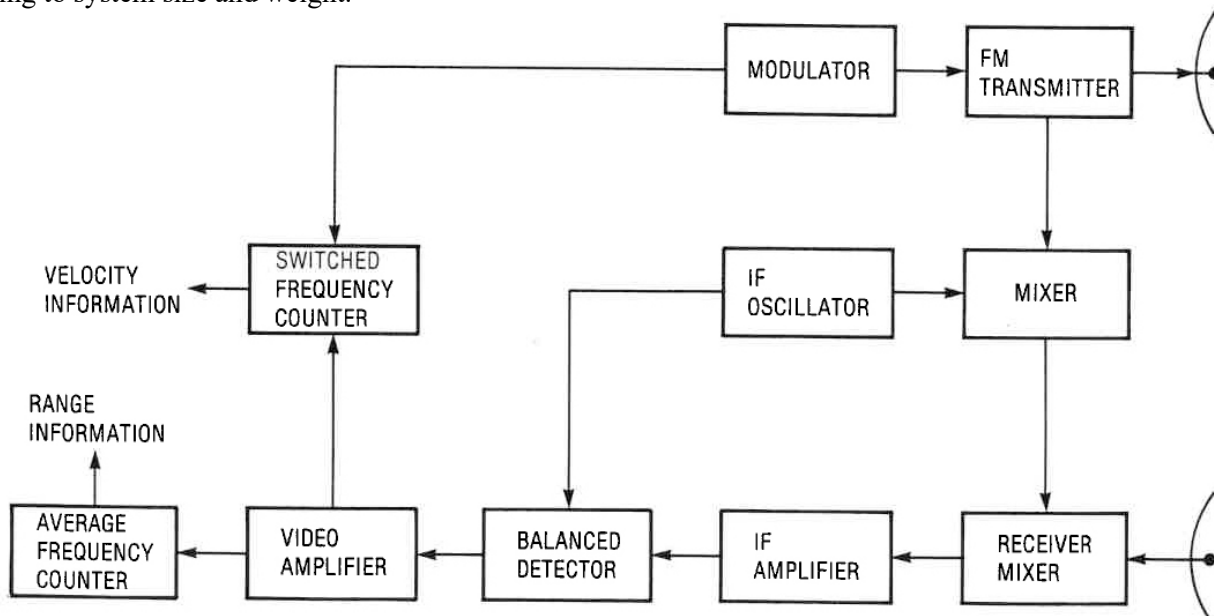
## Pulsed Systems

### Elements of Pulse Modulation

A pulsed radar can be considered an expansion of a CW radar with increased transmitted-spectrum bandwidth accomplished by pulse modulation. Pulse modulation is generally applied, as shown in **Figure 16**, at a periodic rate known as the Pulse Recurrence Frequency (PRF).



**Figure 16.** Pulse modulation terms.



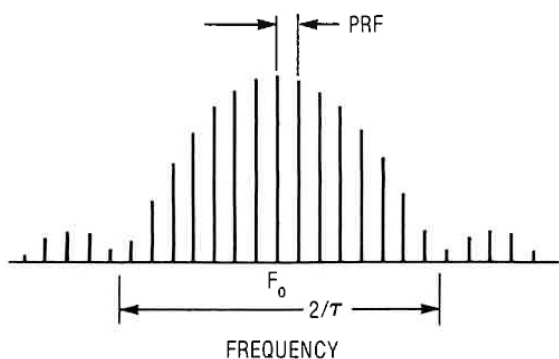
**Figure 12.** Velocity measuring radar block diagram.

Output power of a pulsed radar is related to both pulse width and PRF. Peak output power,  $P_0$  in **Figure 16**, is related to the average output power by the formulas:

$$\text{Pulse Width} \times \text{PRF} = \text{Duty Cycle}$$

$$\left( \frac{\text{Peak}}{\text{Output Power}} \right) \times \left( \frac{\text{Duty}}{\text{Cycle}} \right) = \left( \frac{\text{Average}}{\text{Output Power}} \right)$$

The transmitted spectrum, (**Figure 17**), shows the energy distribution in the PRF sidebands and the relationship of the pulse width,  $T$ , to the width of the transmitted spectrum.



**Figure 17.** Pulsed radar frequency spectrum.

Example: Assume a radar has a peak output of 1 megawatt, a pulse width of 1 microsecond, and a PRF of 1000 hertz. By substituting these values into the above formulas, we can determine the average output power as follows:

$$\text{PW(sec)} \times \text{PRF(Hz)} = (1 \times 10^{-6}) \times (1 \times 10^3)$$

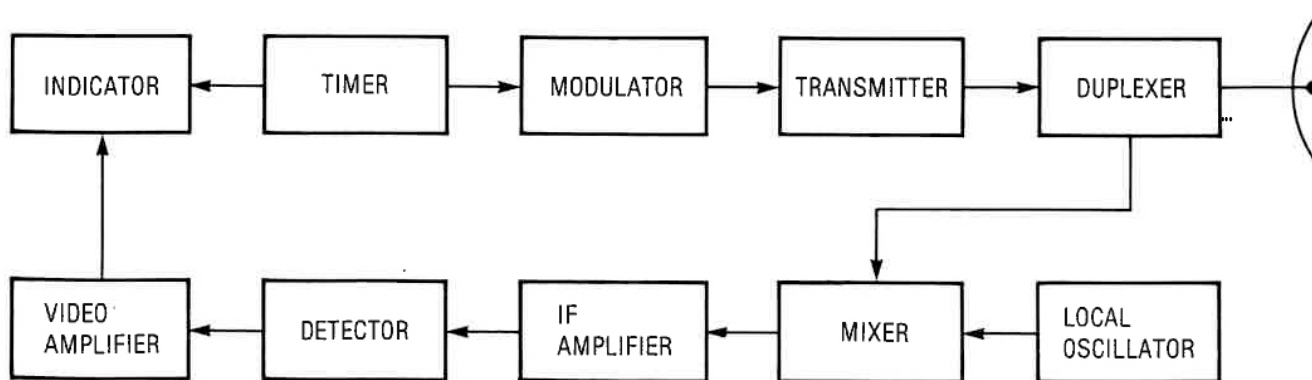
$$= 1 \times 10^{-3} \text{ Duty Cycle(Du)}$$

$$P_0(\text{W}) \times \text{Du} = (1 \times 10^6) \times (1 \times 10^{-3})$$

$$= 1 \times 10^3 \text{ W(average)}$$

The basic advantage of a pulsed radar is that it provides a time interval during which the measurement of range can be accomplished by measuring the time it takes for a signal to propagate to the target and return. As mentioned previously, if a continuous transmission is interrupted, ambiguous information results. In this case, if only one pulse were transmitted, any measured range (in terms of time) would be unambiguous. However, as soon as a second pulse is transmitted, unambiguous range is limited to the time period of the interpulse period. For example, a radar with PRF of 1000 hertz and a pulse length of 1 microsecond has an interpulse period of 999 microseconds. Knowing that a radar signal propagates at a one nautical mile per 12.34 microsecond rate (round trip), 81 nautical miles ( $999/12.34$ ) can be measured before the next pulse is transmitted. This is the maximum unambiguous range of the radar. **Figure 18** shows a block diagram of a typical pulse radar system.

A radar produces a transmitted pulse by turning on a microwave power tube with a pulse voltage generated by a voltage modulator. The voltage modulator is timed by a continuously running timing oscillator that provides timing pulses to the voltage modulator and to the indicator at the pulse recurrence frequency. The transmitter produces pulses of RF energy to the antenna through the duplexer at the PRF rate. A return signal is routed through the duplexer to the superheterodyne receiver where it is detected as a pulse, amplified and applied to the indicator. The timing pulse starts a sweep on the cathode ray tube in the indicator and the target then modulates the sweep at a time corresponding to the range of the target. This simple radar then can provide range information and, knowing the direction of the antenna,



**Figure 18.** Pulsed radar system block diagram.

azimuth information. In the case of **Figure 18** the detector is an envelope detector, similar to AM radio, and phase information is lost in the detection process. This is referred to as a non-coherent radar.

### Transmit-Receive Switching

A pulsed radar system can use one antenna, instead of two as required in CW systems, by using a duplexer, a device incorporating fast switches (gas tubes) to connect the transmitter to the antenna during the transmitted pulse, and then connecting the receiver to the antenna during the interpulse period. Gas tubes are called TR and ATR tubes and accomplish the switching action by the ionization and de-ionization of gases. The ionization and "recovery" times of these tubes play an important part in the achievable minimum range and receiver sensitivity characteristics of a radar system. Solid-state and ferrite devices are now being used frequently in radar systems to supplement or replace gas TR and ATR tubes.

### Minimum Range Considerations

Some radar systems desire to "see" targets at very close ranges. When range measurement is made by using a pulsed waveform and by measuring the elapsed time between the transmitted pulse and the received signal, there are limitations to the minimum range that can be measured. The pulse width is one limitation, since the receiver cannot receive a signal until the transmitter pulse is turned off. Another limitation is the time required to turn the receiver on after the transmitter is turned off. The latter is referred to as the recovery time and is dependent upon the switching performance of the TR and ATR tubes (or whatever devices are used) in the duplexer.

The minimum range as a function of pulse width is simply  $c\tau/2$  ( $c$  = velocity of light,  $\tau$  = pulse width), as the signal propagates from the time of the leading edge of the transmitted pulse. Hence, a one-microsecond pulse limits the minimum range to 492 feet ( $984\text{ft/s} \times \frac{1}{2}$ ). In other words, during a one-microsecond pulse, the pulse energy from the leading edge of the pulse has time to travel 492 feet and return while the transmitter is still on. If another microsecond is needed for switching, the minimum range increases to 984 feet. A radar system that must have short range capability must use a very short pulse width and

have optimum receiver recovery time. To achieve shortest recovery time, a separate and isolated receiver antenna may be employed to eliminate the recovery time of switching devices.

### Receiver Bandwidth

A radar receiver must be designed to extract the maximum information out of the return signal. The bandwidth of the receiver is related to the bandwidth of the transmitted signal, usually by a factor approximating the reciprocal of the pulse width. (A radar with a one-microsecond pulse width must have a receiver bandwidth of at least one MHz in order to best utilize the energy in the pulse signal.) Pulse width is a good indication of the use of a radar, since it provides some indication of the range resolution that is desired. As an example, if a short pulse width (100 nano seconds) is used for increased resolution; wider bandwidth receiver components are required.

### Pulse Compression

The average transmitted power of a given radar may be increased (to increase detectability) by increasing the length of the transmitted pulse. However, a longer pulse width decreases the range resolution capability of the radar. In order to provide increased pulse width without compromising range resolution, a technique is used that provides for the transmission of a long pulse that can be compressed into a short pulse length in the receiver. This technique is called Pulse Compression.

Pulse Compression can be accomplished either by using a linear FM modulation or by phase coding the RF signal during the pulse.

Linear FM (sometimes called "chirp") pulse compression is accomplished by linearly modulating the RF signal during the pulse and then compressing the returned pulse by passing it through a delay line whose velocity of propagation is a function of frequency. In this way the RF signals "bunch up" to form a shorter pulse length.

A block diagram of a typical compression radar is shown in **Figure 19**. The waveforms involved in the pulse compression technique are shown in **Figure 20**. The effective pulse length is compressed to a pulse length of  $1/\Delta F$  and the instantaneous peak power is increased by a factor of  $\sqrt{\Delta F\tau}$ .

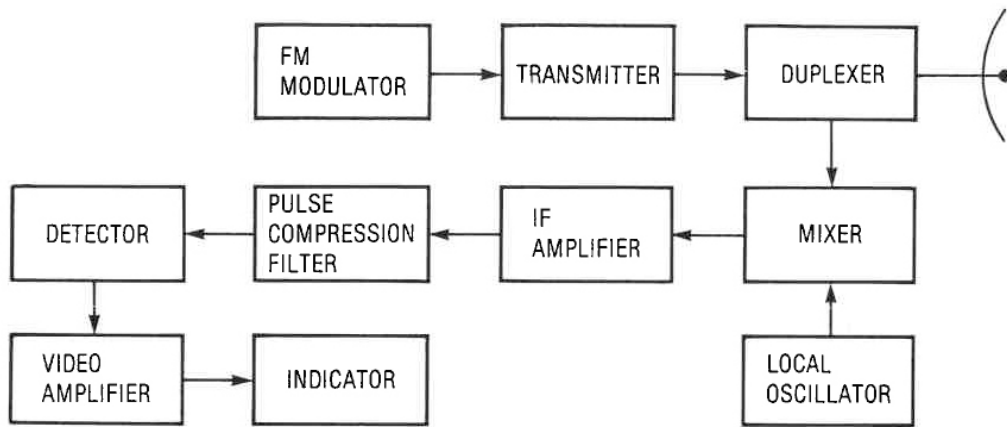


Figure 19. Pulse compression radar block diagram.

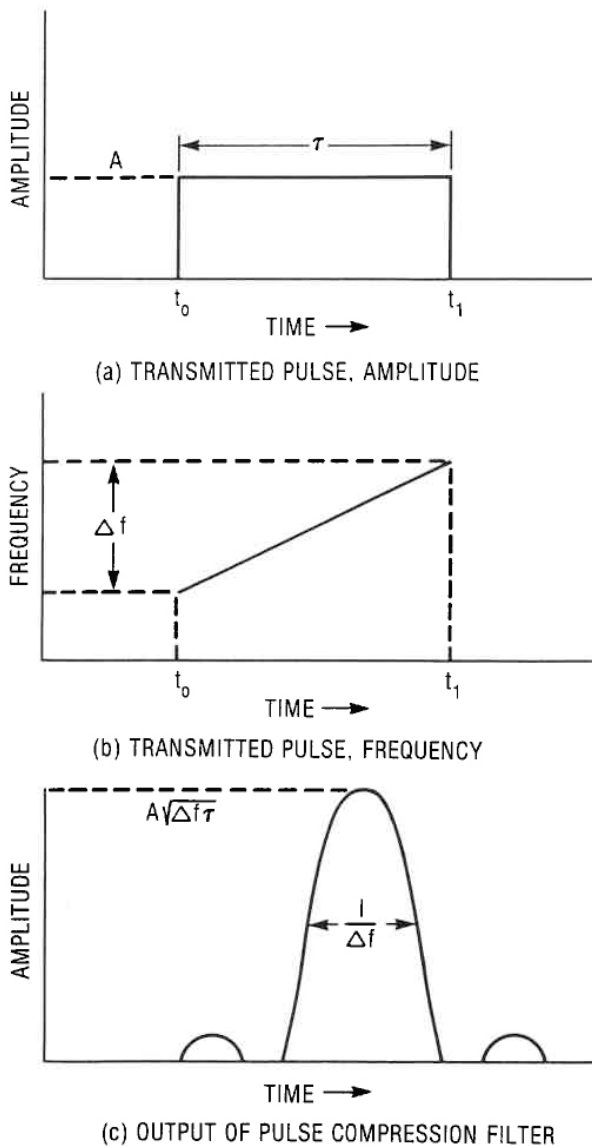


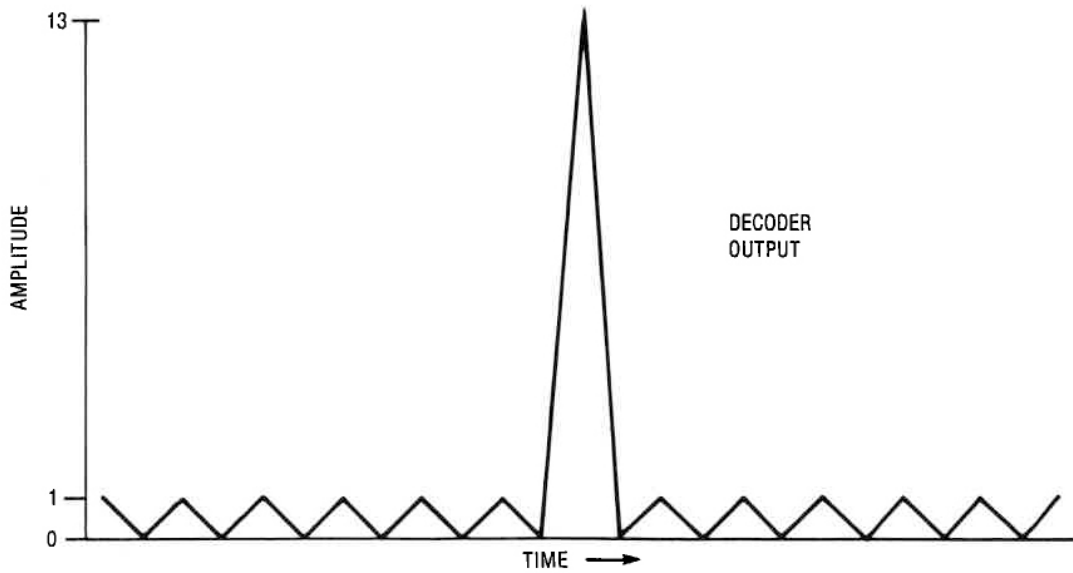
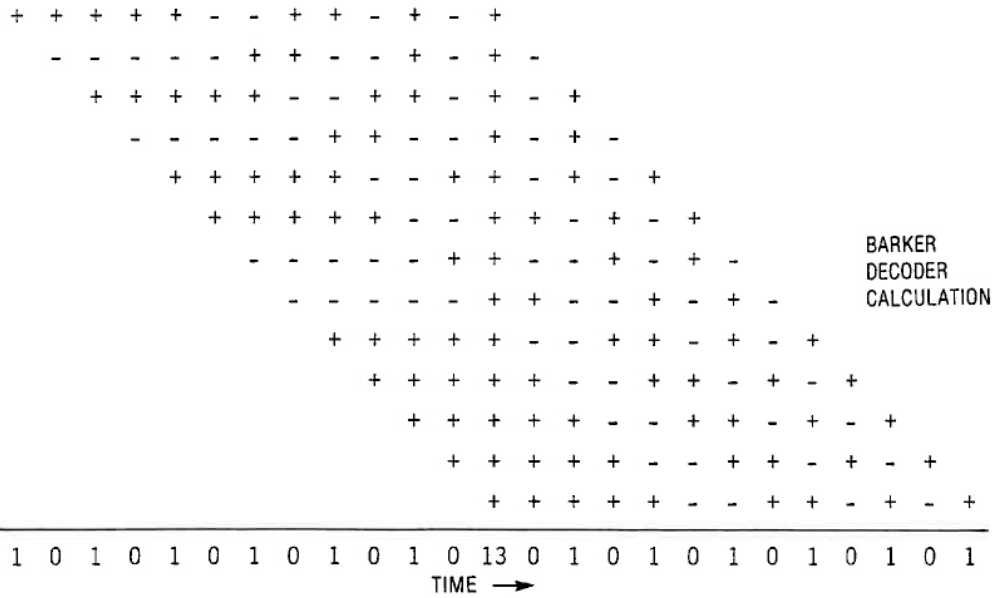
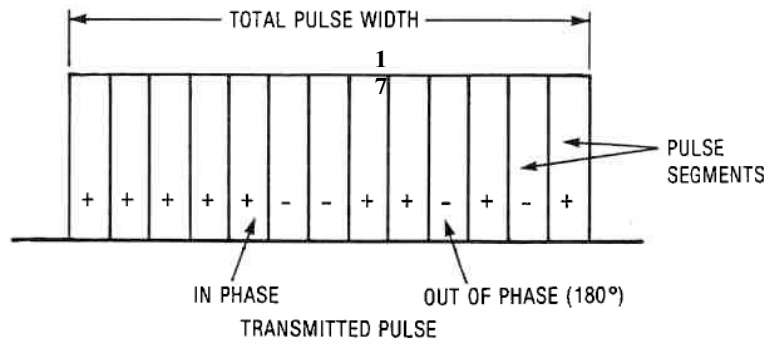
Figure 20. Pulse compression radar parameters.

Pulse compression circuitry adds some complexity to the radar system and makes the transmitter and receiver somewhat more expensive. Larger compression ratios require wider bandwidth components, such as transmitter tubes, and care must be taken to assure the waveform is accurately reproduced as it is amplified in the transmitter. A difference between the transmitted frequency-versus-time waveform and the frequency-versus-time characteristic of the delay line will result in the **time** side lobes of the compressed pulse to increase and present a problem in spurious target information.

Radars are in operation with as much as 1000 MHz of modulation in a linear FM pulse compression mode. This would equate to about 6 inches of range resolution. With that kind of range resolution, discrimination radars can then look at particular sections of a target in order to establish a radar "signature" of a target.

Pulse compression can also be accomplished using digital techniques in which a pulse length is divided into sections and each section is phase coded. **Figure 21** shows a BARKER 13 code, one commonly used binary code to achieve an improvement in range resolution.

More complex codes can be used such as a Frank code, which is a quadrature phase code, wherein the pulses are coded in 90-degree variations. A binary code suffers in performance in time side-lobes with targets with high Doppler frequency shifts, as the Doppler return from the target shifts the phase coding so that in the extreme case, the phases at the end of the code are shifted 180 degrees. This amount of Doppler is referred to as the critical velocity at which the main lobe amplitude is seriously reduced while the time side lobes increase.



**Figure 21.** Digital pulse compression – Barker 13 Code.

## Frequency Agility

A target can be considered to be a number of point scatterers wherein the amplitude of the wave of energy reflected from the target is dependent upon the phase relationships of the reflections from the many point scatterers. If enough independent "looks" can be taken of the target; i.e., independent radiations at different frequencies to provide different reflective phase combinations, then the summation of these independent "looks" will result in a better target return than if the same number of "looks" were taken at one frequency and added in the same manner. This is the basis for designing frequency agile systems for purposes of increasing the detection capabilities of a radar system. Systems are also made frequency agile for reasons of anti-jam capability and for that reason the wider the operating frequency band, the better the anti-jam capability can be.

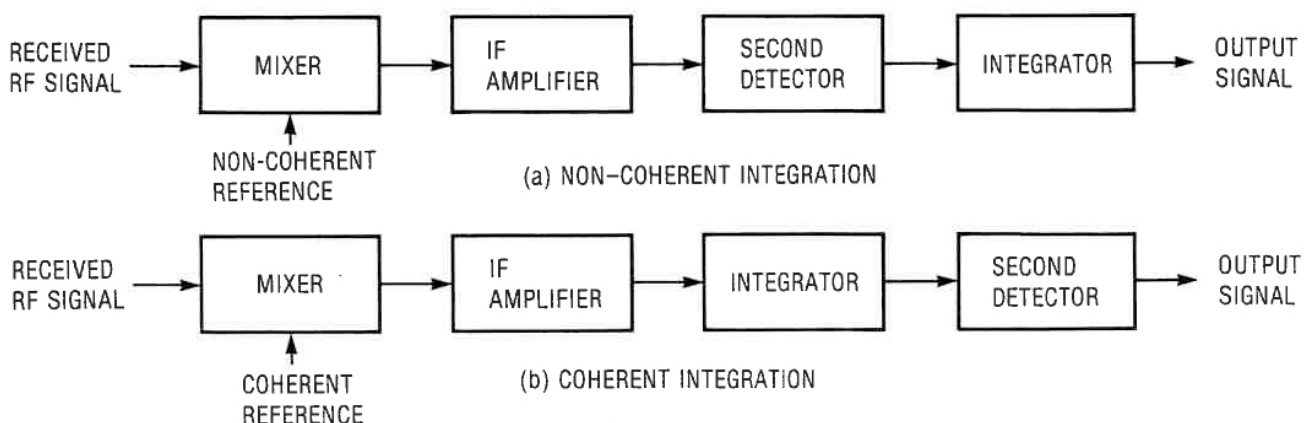
To improve the detection capability, the frequency need only be changed a small amount, sometimes referred to as "dithering". If a target size is large compared to the resolution cell of the radar, the frequency dither required to achieve the detection improvement is approximately equal to the reciprocal of the pulse width. Thus, a system with a 0.5 microsecond pulse width would require only a 2 MHz frequency dither for improved performance. If the target size is smaller than the resolution cell of the radar, the required frequency dither is a number approximating  $150/D$ , where  $D$  is the target size. Thus, a 5-meter target would require 30 MHz of frequency dithering. The change of frequency need not be periodic or random but at least 20 pulses out of the total pulses occurring during an integration period should be displaced by the critical frequency separation. Improvements of 6 to 10 dB in detectability due to

frequency agility has been reported. The generation of frequency agile transmissions is not difficult in a coherent amplifier type of transmitter, as shown in **Figure 23**. However, in a magnetron oscillator type of transmitter, the local oscillator must be made to follow the shifting transmitted frequency, a problem that requires somewhat complex circuitry and wideband local oscillators, depending upon the degree of frequency agility employed.

Agility in the radiated polarization of the transmitted signal is also of interest in achieving optimum detection performance and is receiving some attention in developmental systems although the improvement in performance due to polarization agility is reported to be less than 3 dB.

## Phase Coherency

In detecting a target, a radar does not usually depend on just a single returned pulse to provide an indication but depends on the integration or the addition of a number of pulses that are reflected from a target. In a conventional pulsed radar, the received pulses are integrated by using a long-persistent-screen cathode ray tube and the human eye. In this case, the cathode ray tube acts as a storage device for the target information. In more advanced radar, information data is not always displayed on a CRT and another kind of storage device is used to integrate the information. Integration of signals can be performed either at the IF frequency (before the second detector) or at the video frequency (after the second detector). If the integration is performed at the IF frequency, it is called pre-detection integration or **coherent** integration; integration at the video frequencies is called post detection or **noncoherent** integration. See **Figure 22**.



**Figure 22.** Coherent and non-coherent Integration.

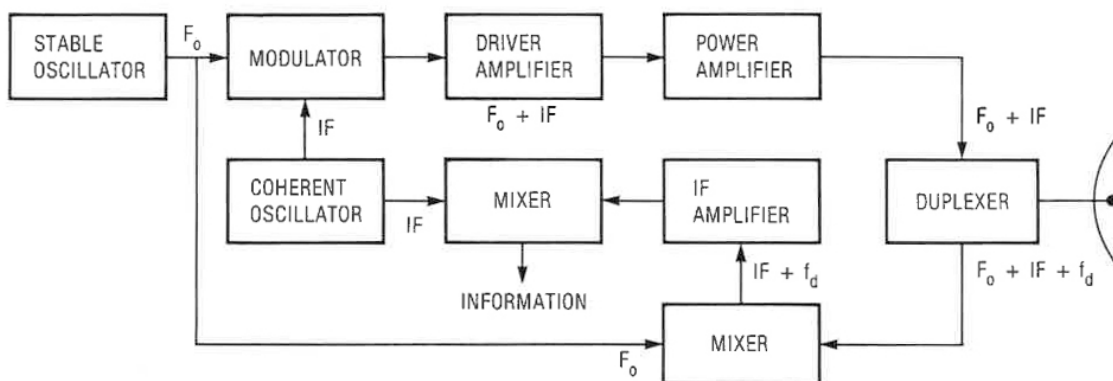
Since the second detector's output is a rectified envelope of the pulse, phase information is lost, and integration can only be performed on the video pulse. In addition, the second detector can introduce some noise because of inherent non-linearities, reducing the integration efficiency. The coherent integrator preserves the phase information and does not suffer the second detector's loss in signal-to-noise ratio, making it a much better integrator. The coherent integrator requires preserving the phase of the received signal from pulse to pulse which in turn requires a coherent reference signal to maintain the phase relationship between the transmitted and received signals. All other things being equal, a coherent detection system can obtain longer detection ranges than a noncoherent detection system and also affords the measurement of Doppler frequencies, resulting in increased emphasis in the development of coherent systems. A typical coherent system is shown in **Figure 23**.

Systems may incorporate a coherent detection system on a single pulse basis to measure Doppler information.

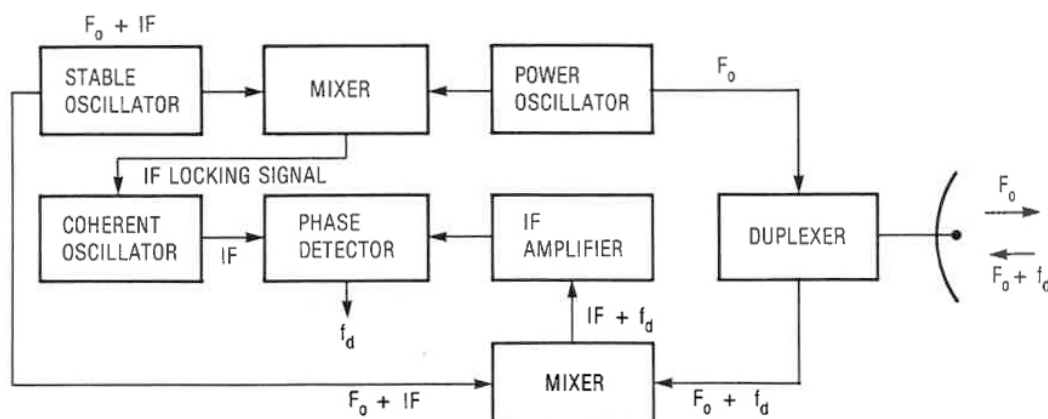
A system using a magnetron transmitter (whose starting phase can be different on each transmitted pulse) can be adapted to provide Doppler information by phase locking a coherent reference signal with each transmitted pulse as shown in **Figure 24**.

### MTI, AMTI, Delay Line Canceller

If an application, such as air traffic control radar, is interested only in moving targets, fixed targets can be effectively eliminated by a technique known as MTI, or Moving Target Indication. This technique takes advantage of the effect that the relative motion of a target has on the reflected radar signal. The fixed targets are reflected at the same frequency as the transmitted signal while the moving target reflections experience the Doppler frequency shift effect. The fixed targets can be regarded as DC signal components and the moving targets as AC signal components and if an interpulse period of information can be delayed a  $1/PRF$  length in time and inverted in polarity, then the fixed-target components can be made to



**Figure 23.** Coherent radar system block diagram.



**Figure 24.** Coherent-on-receive radar block diagram.



cancel out, leaving the moving target components to subtract or add at their respective Doppler rates, depending on phase. **Figure 25** shows the process of extracting moving target information using a delay line cancellation technique.

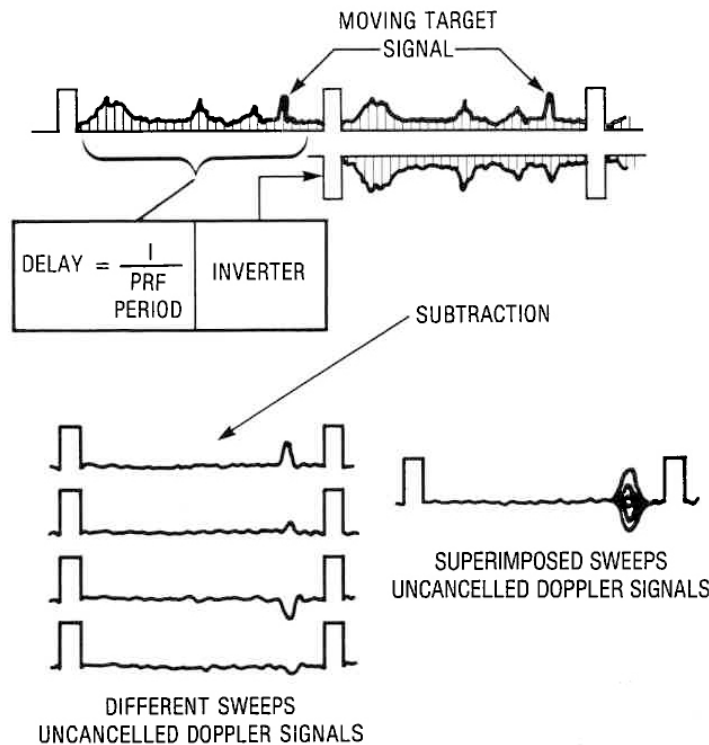
In a radar employing an MTI detection system, the range information is unambiguous within the interpulse period. However, it can be seen that, in a pulsed radar, some velocity information becomes ambiguous, since any target velocities with Doppler frequencies corresponding to the pulse recurrence frequency and the multiples of the pulse recurrence frequency (see **Figure 1**) will not be "seen" by the receiver and are known as "blind speeds". This may be better explained by saying that any Doppler shift at the PRF frequency or at multiples of the PRF frequency will not be discernible from the returned signals of the transmitted spectral PRF lines. The number of blind speeds of an MTI radar can be reduced by employing different or staggered PRFs on a time-sharing basis.

An MTI function in an airborne radar (AMTI) is somewhat more complex than in a fixed-location radar system, since in an airborne radar all targets have some Doppler frequency shift. Thus, a Doppler "bias" frequency must be applied to subtract

out the vehicle's velocity component so cancellation can occur in the same manner as fixed targets and clutter are cancelled in ground-based radars. The problem gets more complex when the applied Doppler correction frequency must be changed when the antenna scans off the boresight position, since the Doppler frequency shift in the return signal varies with the direction the antenna points.

### Range-Gated MTI

Radar equipment data processing methods take advantage of the digital data processing techniques that have been rapidly advanced by the computer industry. Because of the Doppler Effect, moving targets reflect a radar signal with a small frequency shift relating to the relative radial velocity of the target to the radar. Therefore, the existence of a Doppler frequency shift in a returned signal can be used as a digital difference between stationary and moving targets. The Doppler frequency shift is detected by standard frequency domain detection methods and is used to apply a video signal to an indicator. While the "moving target" signal is detected in the frequency domain, the time relationship to establish the range of the target is accomplished by sampling small segments



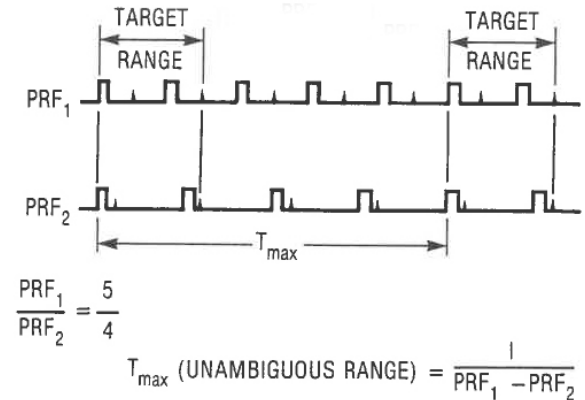
**Figure 25.** Delay line type of moving target indication.

of range by sequential time gating of the receiver. In this way, a signal that is detected with a Doppler frequency shift can be displayed on an indicator at a range position corresponding to the time of the "on" gate of the receiver during which the signal is received. All signals that are received from stationary targets can still be detected with standard amplitude detection methods and viewed on a separate indicator or processed as separate video signals. Most importantly, stationary target signals do not appear in the output of the frequency domain detector. Thus, the ratio between moving and stationary signals is improved substantially over a conventional delay line cancellation technique. The range-gated MTI system requires good frequency and phase stability during each PRF period to prevent the generation of false Doppler signals that would give rise to false moving targets or raise the level of the video threshold. Accordingly, range-gated MTI systems use very stable microwave amplifiers to achieve coherent operation with good continuous phase relationship during the PRF period.

### Pulsed Doppler Radar Systems

A pulsed Doppler radar system and a pulsed radar system with MTI operation are quite similar, i.e., both systems are trying to obtain both range and velocity information. The real difference is that the pulsed Doppler radar extracts unambiguous **velocity** within finite limits at the cost of ambiguous range information. The MTI radar has been described as extracting unambiguous **range** information within finite limits at the cost of ambiguous velocity information. In fact, many MTI radars do not measure the Doppler frequency if only objective is to separate moving and fixed targets. The pulsed Doppler radar is designed to extract Doppler information for purposes of finding and tracking a target in a high clutter environment and during high closing rate situations. An important feature of a pulsed Doppler system is its capacity of detecting the presence of a frequency rather than detecting a signal above a determined amplitude level. This feature makes it an inherently automatic device that can detect signals at very low levels. Pulsed Doppler radars are characterized by high pulse recurrence frequencies usually in the 10 kHz to 300 kHz range and as in the case of MTI radar, use a technique of changing the PRF to minimize ambiguities, in this case, range. **Figure 26** shows a typical example of switching the PRF to measure the

"second time around" signals and to identify them with the right transmitted pulse.



**Figure 26.** PRF switching for measuring range.

The PRFs that are used have a numerical relationship, such as 5 and 4 or 18 and 19, and will be dependent upon the unambiguous velocity limits to be handled (to avoid blind speeds) and the unambiguous range interval desired. **Figure 26** shows the relationship of two PRFs and the maximum unambiguous range interval. A typical block diagram of a pulsed Doppler system is shown in **Figure 27**.

### Monopulse Radar Systems

In order to track a target, the radar must be able to discern the position, relative to the antenna boresight, of the radar return signal. Early radars mechanically scanned the target area from which an amplitude modulation of the returned signal was produced to sense the target's position. One popular antenna scan pattern was a conical pattern that resulted in a sinusoidal amplitude modulation of the returned signal whose phase and amplitude were dependent upon the target's position in the scan pattern. By servo control of the antenna's boresight position to minimize the modulation, the antenna could be made to point at or "track" the target. This technique is fairly easy to deceive with ECM equipment and has obvious mechanical drawbacks. A much better technique that now is used that eliminates the mechanical scanning is called monopulse tracking. The monopulse tracking antenna technique is far more difficult to deceive in terms of its pointing capability.

A monopulse radar system is a tracking radar that derives all its tracking error information from a single pulse. In addition, new and independent

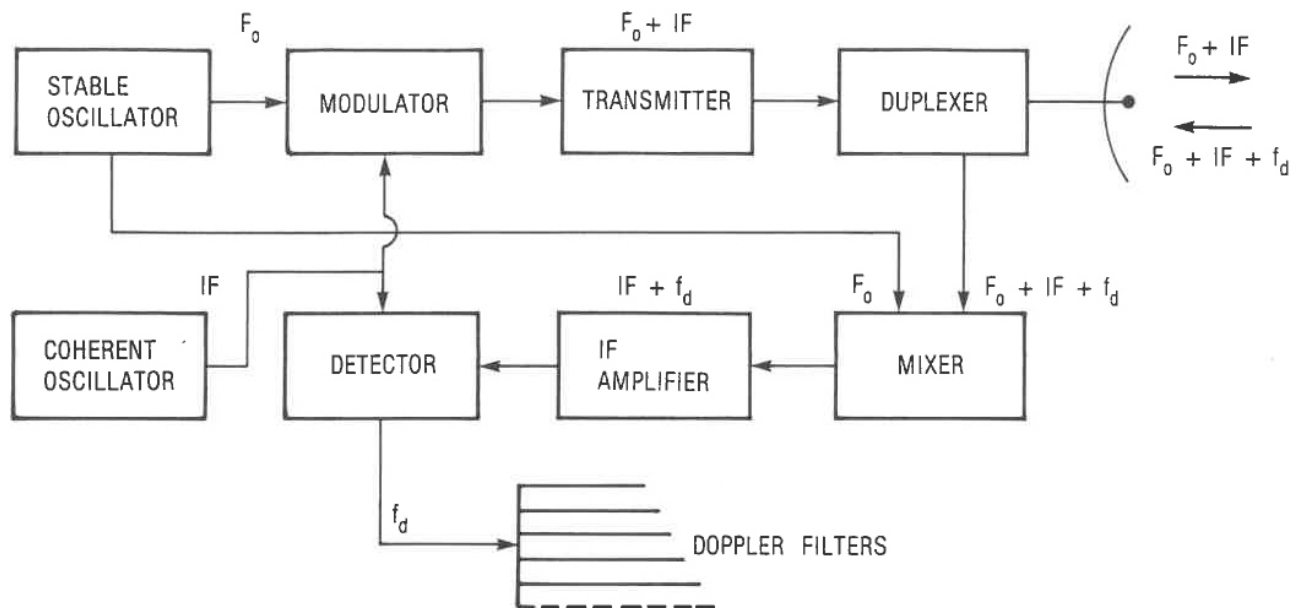


Figure 27. Pulsed doppler radar block diagram.

error information is generated with each new pulse. The basic principle of monopulse radar is that of combining the RF circuits of two antenna patterns to simultaneously obtain both sum and difference signals. The antenna patterns overlap as shown in Figure 28a. The sum of received signals of the two antenna patterns are shown in Figure 28b and the difference of the received signals in Figure 28c.

Physically, two antennas are not necessary since the "arithmetic" can be accomplished with a single parabolic reflector and two radiators, or "feeds," displaced from the focal point of the antenna.

The sum pattern is used for transmission of the pulse while both the sum and difference patterns are used to receive the pulse. Figure 29

shows a block diagram of a single-coordinate system.

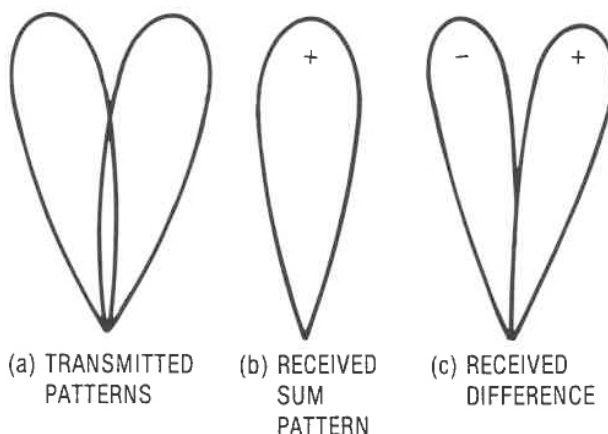


Figure 28. Monopulse radar antenna patterns.

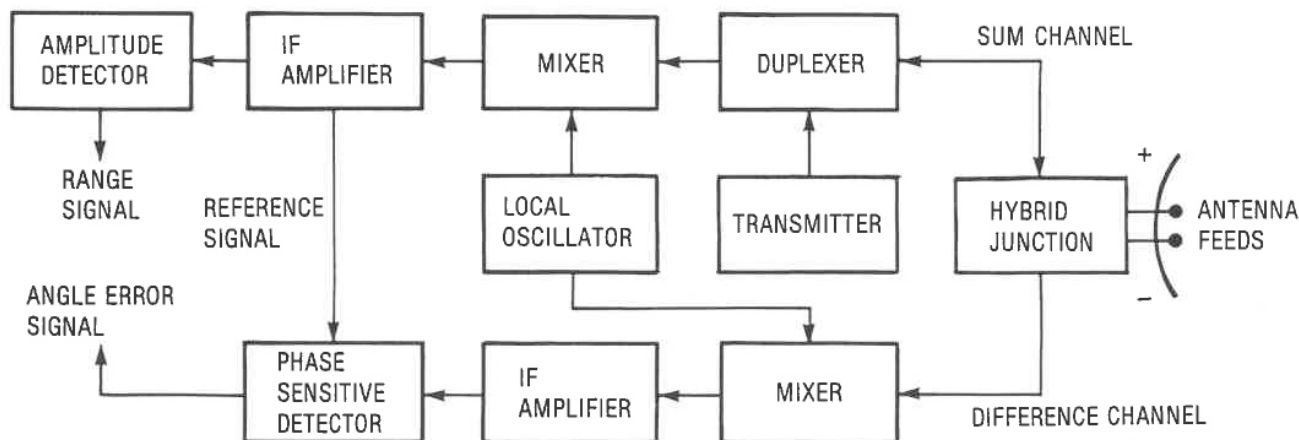
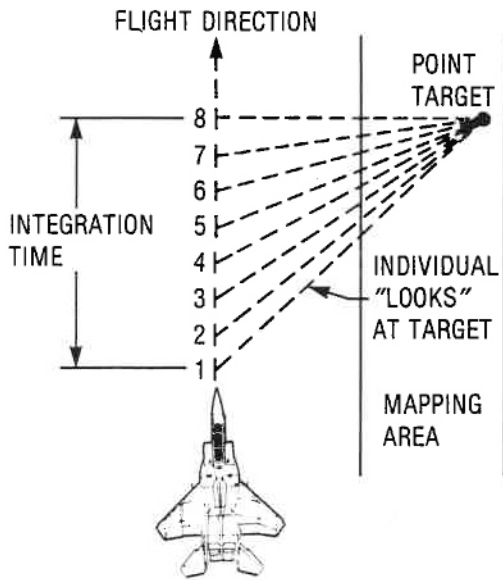


Figure 29. Amplitude-comparison monopulse radar block diagram.

The difference pattern signal provides the **magnitude** of the angle error while the sum pattern signal provides the reference needed to extract the **sign** of the error signal. The sum signal also provides a means of extracting the radar range measurement as in a conventional pulse radar. If two-coordinate information is desired (azimuth and elevation), then four (or even three) antenna feeds can be used to provide the sum and difference patterns in quadrature. Most current airborne tracking radars use some kind of monopulse method for tracking targets.

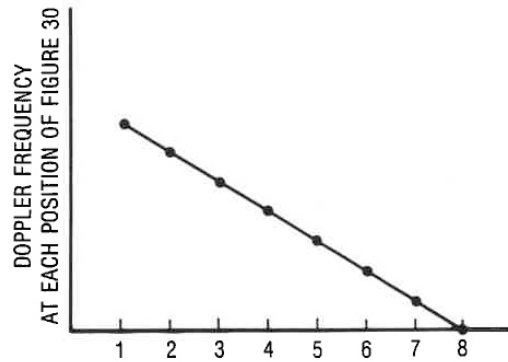
### Synthetic Aperture Radar Systems

A synthetic aperture radar is one that employs a means of obtaining increased azimuth or angular resolution by using the technique of a synthetic aperture antenna. The main application of this radar technique is that of high-resolution radar mapping. The synthetic aperture antenna is the name given to a method of transmitting and receiving where the motion of the vehicle traveling in a straight line effectively creates a linear array of antenna elements as the vehicle moves through a specified time period (see **Figure 30**). The target information received in this time period is stored and later processed to achieve an increase in angular resolution.



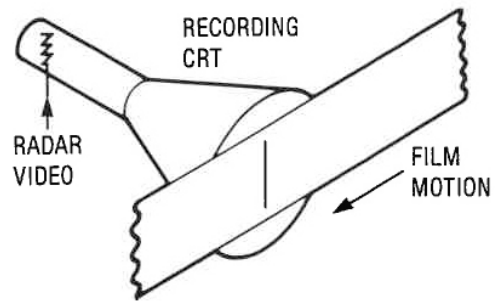
**Figure 30.** Synthetic aperture antenna.

The Doppler frequencies received from a point-target return signal will decrease as the vehicle approaches a perpendicular range position (**Figure 31**, Position 8) where the Doppler signal will be zero. The Doppler history of the point target as shown in **Figure 31** corresponds to the positions indicated in **Figure 30**.



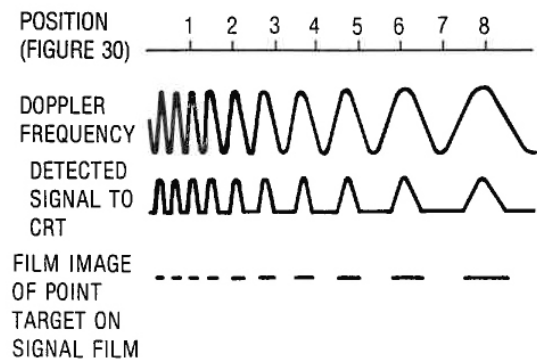
**Figure 31.** Doppler frequency history of a point target.

The Doppler histories of the target area are recorded on signal film by a photographic process as shown in **Figure 32**.

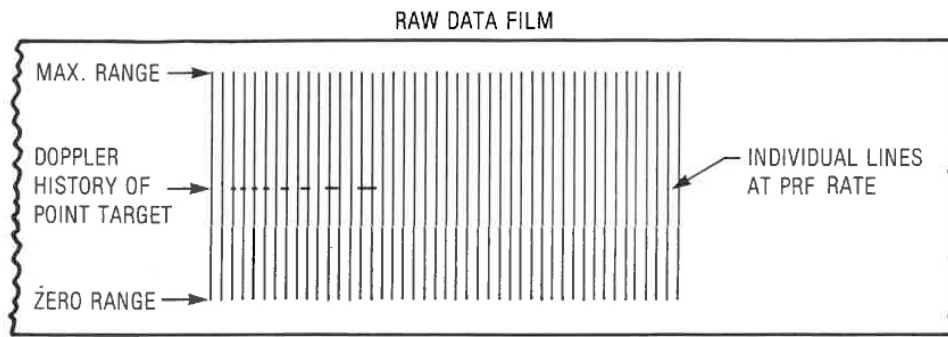


**Figure 32.** Recording of Doppler signal on raw data film.

A line is scanned on the film at the PRF rate. The vertical position then corresponds to range. The signal strength of the targets provides density modulation of the film (exposure). A simple drawing of the Doppler modulation and how it is recorded on film is shown in **Figure 33** corresponding to the Doppler history of **Figure 31**. The signal film then stores a Doppler history of each point target at its particular range as shown in **Figure 34**. The signal film is then processed in an optical processor to produce a radar image film, which in turn is used as a negative film to produce a photographic image, a radar map picture.

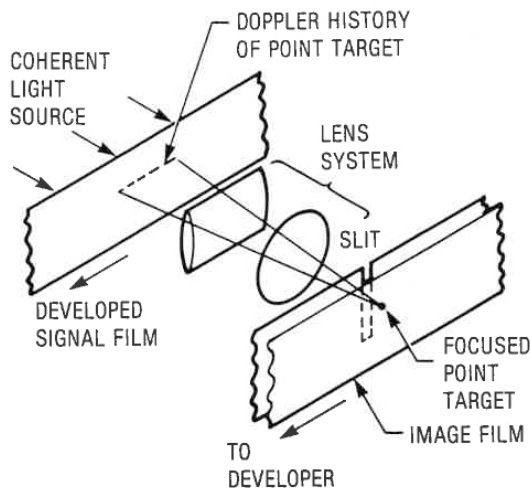


**Figure 33.** Doppler signal modulation of signal film.



**Figure 34.** Synthetic aperture antenna radar signal film.

Each Doppler history performs as an individual Fresnel lens and when the signal film is illuminated by a coherent light source, such as a laser, each point target is focused on the image film as a point as illustrated in **Figure 35**. The entire radar map is made up of the integration of all the point targets and the angular resolution is then a function of the resolution capability of each point target. Of significance is the ability of the radar to maintain optimum resolution that is independent of range, referred to as having a "focused" antenna.



**Figure 35.** Fresnel lens effect on focusing point targets.

The range resolution of the synthetic aperture radar is achieved by pulse compression techniques. Thus the radar employs the ultimate in range and angular measurement techniques and provides the best radar resolution achievable in the present state of the art.

The disadvantage of the synthetic array radar of the 1970s, as described, was the time required to obtain the final radar image. It is not a "real-time" radar, or one where the radar image is instantly available as in standard radar systems.

In this case, the signal film is either physically returned to a processing facility or the radar data is transmitted to a processing facility which then produces an image film and radar map pictures.

The current technology of digitally processing radar data has been applied to synthetic aperture radars and together with the present capability of storing large amounts of data, a real-time display is now achievable. Some compromise in resolution, compared to optically processed data, may be tolerated to achieve a real-time display but present systems are achieving remarkable results. The use of the synthetic aperture principle to targeting air-to-ground weapons is another important application of a real-time high-resolution radar mapping system.

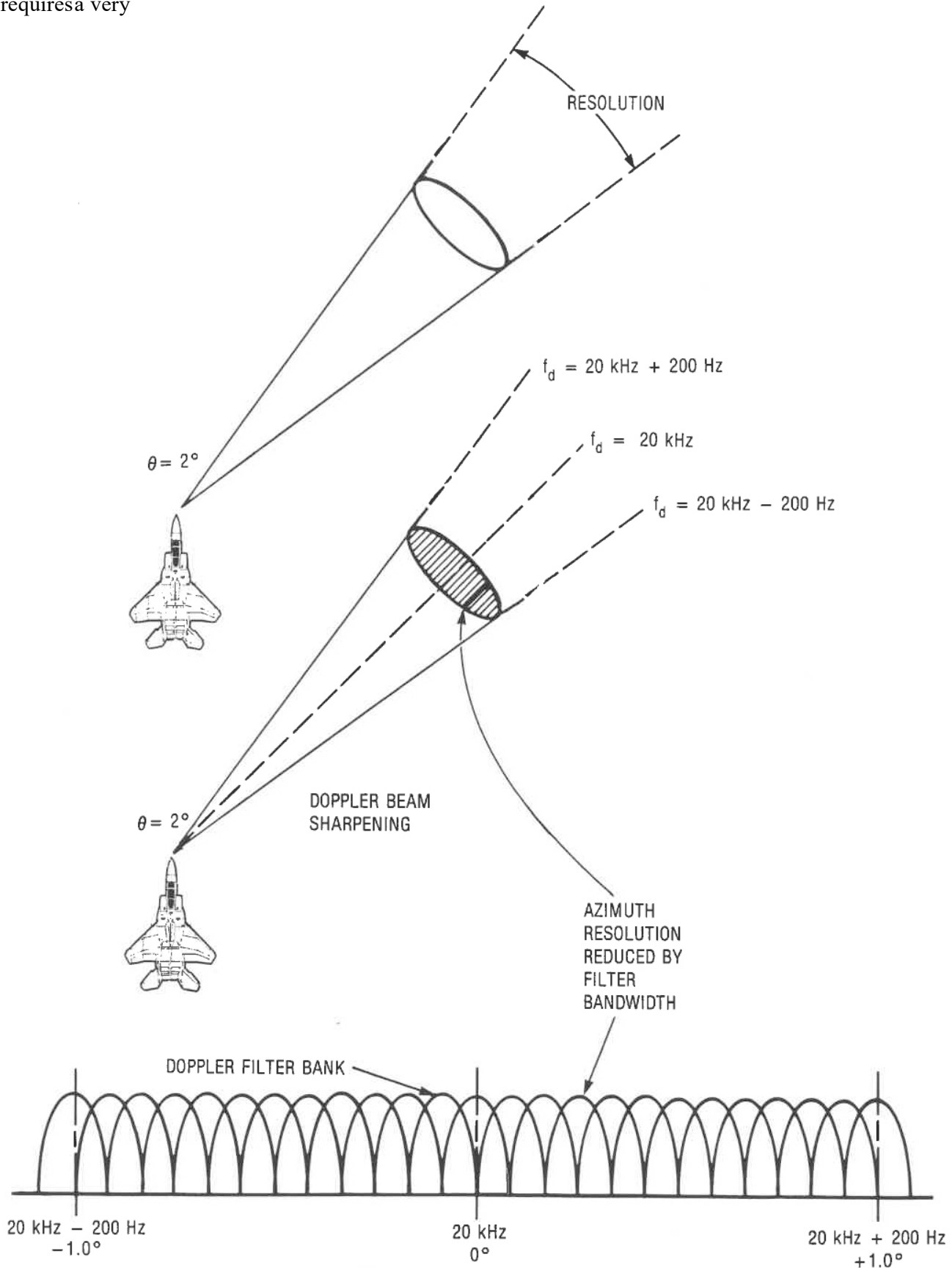
A further advantage of the synthetic aperture technique is that of being able to detect rotational Doppler information of a target that is also moving relative to the radar. This capability provides an image of the target that is more likely to provide a means of target identification than previous radar identification attempts. This technique is called Inverse Synthetic Aperture Radar (ISAR).

### Doppler Beam Sharpening

Doppler beam sharpening is a radar technique that is used to improve the azimuth resolution of a radar. Where the usual azimuth resolution is dependent upon the beamwidth of the antenna, in the case of Doppler beam sharpening the beamwidth is divided up into segments by using many Doppler filters and by processing the receive signals using Fast Fourier Transform (FFT) techniques. The signal returns within an antenna beamwidth can be sorted because of the differences in the Doppler frequencies within the

beamwidth (see **Figure 36**). That is, a target can be identified within the beamwidth by its particular Doppler frequency. This technique requires a very

stable transmitter and coherent signal processing, as it is necessary to introduce a constant Doppler frequency offset so that the Doppler frequency



**Figure 36.** Doppler beam sharpening.

associated with the azimuth cursor is translated to zero frequency. The phase correction is derived from the aircraft velocity, the depression angle as well as the azimuth angle. Radar systems employing Doppler beam sharpening can use either fully coherent systems or, in the case of magnetron transmitter systems, they can be made to operate with a coherent-on-receive type of radar system.

### **Bistatic Radars**

**Bistatic** radars by definition are radars that employ separate and widely spaced transmitting and receiving antennas rather than the normal single transmit/receive antenna used in **mono-static** radars.

Although a monostatic radar overshadows the bistatic radars in performance, the bistatic radar has special advantages that makes it quite attractive for particular applications.

The monostatic radar has the real disadvantage of being easily detected by its emission. Monostatic radars can be jammed or even targeted by antiradiation missiles that passively home on the radar's emission. The obvious advantage then of a bistatic radar is that its transmitter is located well away from the receiver and can be in some remote place where it is not adversely affected by jamming or by destruction from an ARM missile. If jamming is directed toward the radar transmitter, as is the normal case, then the receiver is effectively untouched by the jamming signal. However, a bistatic radar system would not be effective if the jamming is omnidirectional. The key technical issues having to do with the designs of bistatic radar involve the complexity of the geometry, the difficulty of controlling it, and the difficulty of implementing the synchronization, isolation and the platform locations. Part of the difficulty that arises in a bistatic system is that the illuminators and receivers are usually moving and are difficult to coordinate, especially in a hostile environment. In addition, the transmitter and the receiver and the target must all be visible to each other so that any obstacles of terrain and the horizon do not interfere with the required mutual visibility. The position of the illuminator with respect to the receiver is needed to solve the bistatic triangle (see **Figure 37**) between the illuminator, receiver and the target and it becomes very difficult when an illuminator is aboard an airplane,

for example, as it is continually changing its position. For coherent operation it is usually necessary for the illuminator to be synchronized with the receiver thus the waveform radiated by the illuminating radar must be available or synthesized at the receiver in order to coherently process the bistatic signals reflected from the target. The constraints faced by bistatic systems at the present time, because of the particular geometries involved, will probably preclude their universal deployment in the near future.

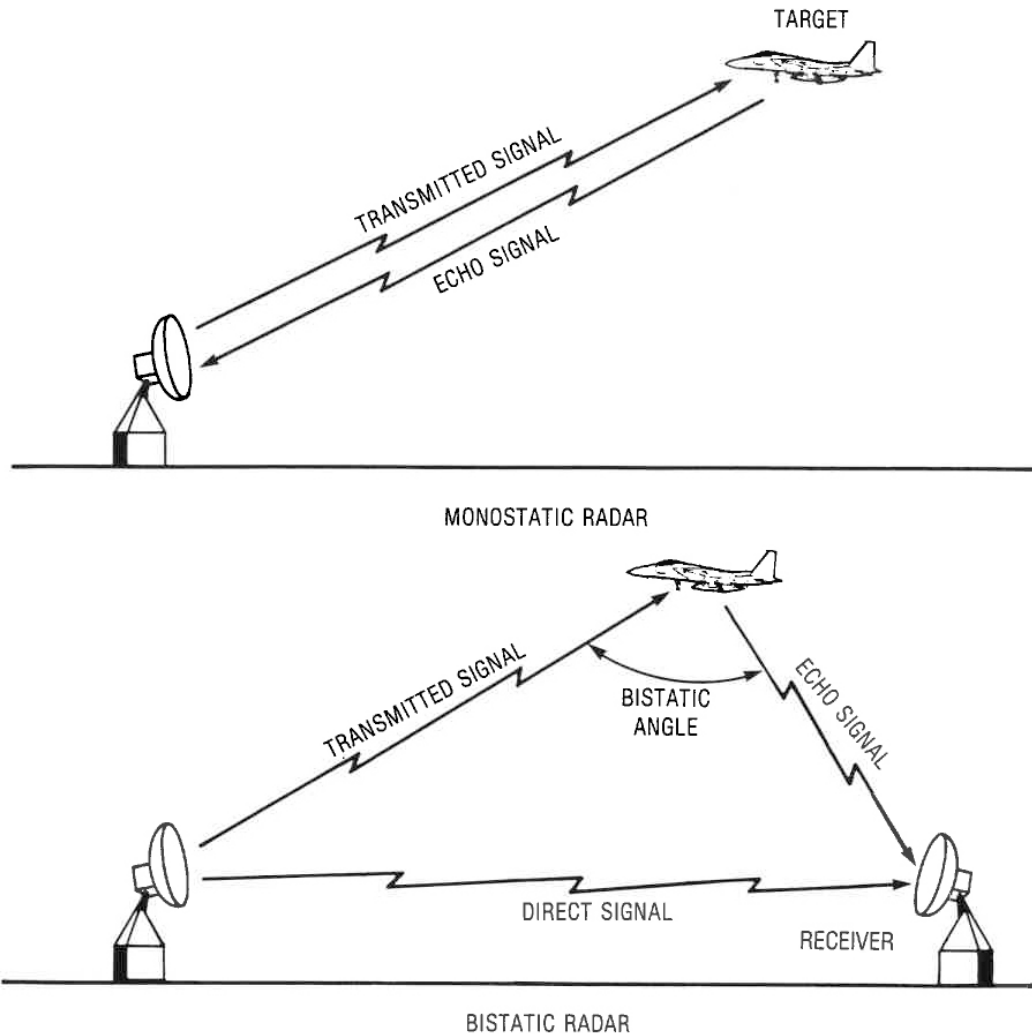
### **Over-the-Horizon Radars**

As microwave equipments are line of sight devices, a radar system is limited to that extent, with the exception of some diffraction and "ducting" effects. In order to detect targets over the horizon at significant ranges, 1000 nautical miles, for example, the radio waves must be "bounced" off the ionosphere as is done in long range radio communications. The radars that are designed to operate accordingly are called **OTH** radars (Over-The-Horizon).

As only lower frequency radio signals bounce off the ionosphere, the OTH radars make use of this propagation technique and operate at HF frequencies of the order of 15 to 20 MHz. The OTH radars employ a very large antenna that requires considerable real estate. The antenna must be high gain, cover a wide frequency range, be steerable in elevation and azimuth and be capable of handling high power. The coverage of the radar on the surface of the earth depends on the ionosphere. For proper coverage, a number of different frequencies may be required and programmable to the ionospheric conditions at a particular time.

The radar's waveform can be Pulse or FM-CW. In the pulse waveform, a long pulse length, such as a millisecond, is transmitted to achieve high average power on the target. The pulse repetition frequencies are low, such as 50 Hz, as the unambiguous range interval must accommodate ranges of several thousand miles.

Generally, a shaped RF pulse is used to reduce spectral energy away from the carrier to minimize interference with other users of the HF frequency band. In the FM-CW case, the transmitting and receiving antennas are located at separated sites at a considerable separation distance in hundreds of miles. This bistatic radar achieves high power output without the high peak power components required of a pulsed radar.



**Figure 37.** Bistatic radar.

OTH radars deal with problems of fading, multiplicity of paths from radar to target, ionospheric changes, auroral ionization and a large scattering area (clutter) that competes with desired target echoes. Given that the environment is sensed in real time and the radar's operating parameters can be adjusted to match the existing conditions, the OTH radar can be a very successful technique for the detection of long-range targets.

### Missile RF Guidance Techniques

There are three types of RF guidance techniques commonly used in air defense guided missiles: (1) Beam Riding, (2) Command Guidance and (3) Homing Guidance.

The **Beam Riding** system is one where the missile does not perceive the target but detects its own position relative to the radar beam that is

tracking the target. The missile keeps itself centered in the radar beam and attempts to hit the target which is also centered in the tracking radar beam. The missile must continuously maneuver to remain in the center of the beam even if the target is flying on a straight-line course. This can result in severe corrective maneuvers during the final intercept phase. Another drawback to the beam rider is that any angular tracking error at the radar becomes a larger error as the range is increased, as the antenna beamwidth increases with range, and therefore the accuracy of a beam rider system is inversely proportional to target range. For these reasons the beam riding technique is mostly used to guide missiles in the early portions of their flight and is used in conjunction with a homing type method.



In a **Command Guidance** system the target is tracked by a tracking radar and the missile does not perceive the target. Another radar will track the missile and the data from the missile tracking radar and the target tracking radar can be fed to a computer which will calculate the missile trajectory required for intercept. The trajectory information is continuously transmitted to the missile to "command" its best flight path. Thus, a more efficient trajectory can be used since the computer can plot the best flight path for the missile. As is the case with the beam rider, accuracy is also inversely proportional to range since a fixed angular error at the radar increases with range.

In the **Homing** type guidance the most widely used technique is that of **Semi-Active Radar Homing** in which an illuminating radar is needed to provide the transmitted energy so that the missile can passively guide on the reflected echo from the target. Thus, the semi-active radar method requires the radar illuminator to be pointed at the target until the missile has impacted.

In acquiring the target, the semi-active homing missile uses a narrow band frequency gate to search the spectrum and to lock on to the signal reflected from the target. The received signal is then coherently detected either against a signal received from the illuminator from a rear antenna in the missile or from a very stable oscillator reference on board the missile. The frequency spectrum of the illuminating radar must be free of any spurious outputs that might occur in the desired Doppler band relating to the velocity between the missile and the target. If the radar illuminator is transmitting a spurious output in the desired Doppler band then it can appear as a false target which could seriously affect missile performance. The noise specifications placed on an illuminator transmitter, especially a CW transmitter, are very severe and require special kinds of low noise klystrons or traveling wave amplifier tubes to meet the requirements.

A second homing method is that of the **Active Radar Homing** method in which the illuminating radar signal is on board the missile and the missile is completely autonomous, sometimes referred to as a "fire and forget" missile. The Homing type missile is considered to be the most intelligent of the three missiles, but it also can require the most complex equipment. Both the active and semi-active homing missile perceives the target with its

own radar receiver and computes its own control signals. One advantage of the homing type missile technique is that as the missile gets closer to the target the quality of target information continually improves as range decreases.

The radar waveforms for illuminating a target can be either CW or pulsed Doppler. CW is the simplest and provides best lower altitude capability by discriminating against clutter on the basis of unambiguous Doppler frequency. A CW system will normally have a number of illumination radars which are directed by a separate tracking radar. Alternately, each can be made to be a self-tracking illuminating radar if two antennas are used. One advantage of a semi-active system is that it can provide much more power output in the illuminating signal when the transmitter is not restricted to the small confines of a missile. A pulsed Doppler waveform may also be used for either an active or semi-active illumination system for which the PRF is chosen high enough to yield unambiguous Doppler data. In a complex system where many targets must be tracked and illuminated, the illuminating signal can be essentially an interrupted CW signal in which the pulse may be of the order of milliseconds in length. In this case the missile would have to operate in a sampling data mode, extracting information during the time its target was illuminated and then holding the information until the next sample.

Although some semi-active missiles home during their entire flight, a homing type guidance system is usually only used during the last seconds of the intercept. Another guidance technique, either command or beam riding, is used during the mid-course of the flight in order to get the missile to an appropriate point where it can acquire the target and enter the terminal homing phase of its flight. This is considered more efficient from the standpoint of radar power in the missile trajectory as the total homing intercept range is reduced accordingly.

The trend in advanced air-to-air missile systems is in the direction of active homing guidance to eliminate the necessity for the aircraft to continually illuminate the target until the missile has impacted. Obviously, the "fire and forget" missile is the more popular choice for pilots. As missiles become more complex then so does the electronic countermeasures that are used to deceive the missiles and thus a number of different sensors and modes of operation are incorporated in advance missiles.

These include multi-modes where a missile can switch to a passive mode and home on the radiated signal ("Home-On-Jam") or can deploy another sensor, such as an IR sensor, to passively home on the target.

Active homing guidance does have the disadvantage of requiring a larger missile to carry the on-board transmitter, impacting on propellant, weight, missile maneuverability and not the least, the cost of the missile.

Semi-active guidance affords a smaller missile but is limited to the line of sight transmission of the illumination signal, requiring an airborne illuminator for intercepts of over-the-horizon targets.

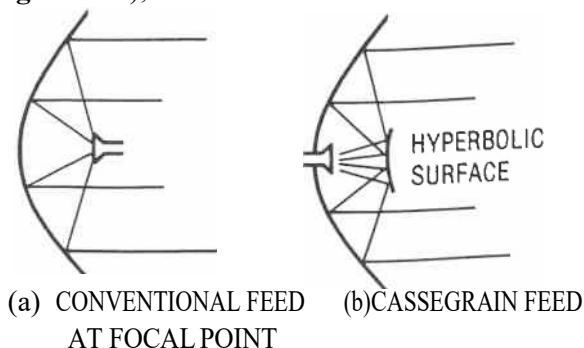
A variation of semi-active homing is called a "Track Via Missile" guidance system (TVM). In this system the missile receives the target's reflected illumination but, instead of processing the signal on board, the signal is retransmitted to the illuminating radar where the radar then computes the guidance information and retransmits a command guidance signal back to the missile. This system is used to handle a larger number of threats.

### Antennas

From the radar equation, it can be seen that the detected radar range depends upon the antenna's gain, aperture and efficiency. Other system factors that enter into antenna design considerations are scanning rate, stabilization, power-handling capability, size, shape, etc.

### Parabolic Reflectors

Most radars use a parabolic reflector of some kind, fed either at the focal point (**Figure 38a**) or at the surface of the reflector in a Cassegrain Configuration (**Figure 38b**), to direct the beam in a focused manner.



**Figure 38.** Parabolic antennas.

Parabolic reflector antenna surfaces are often modified to obtain wider field patterns for greater search areas, especially in airborne radar where ground illumination at all ranges is desired. One type of a modified parabolic reflector often used, is called a "cosecant squared" reflector. It provides a radiated field at both close and far ranges.

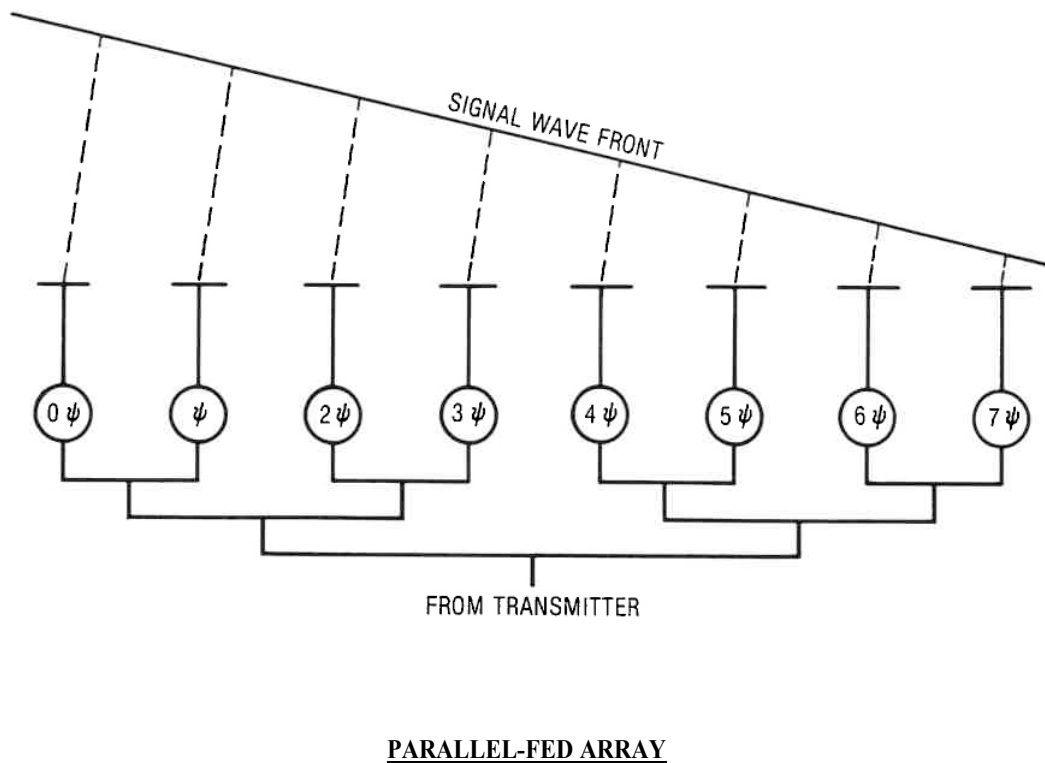
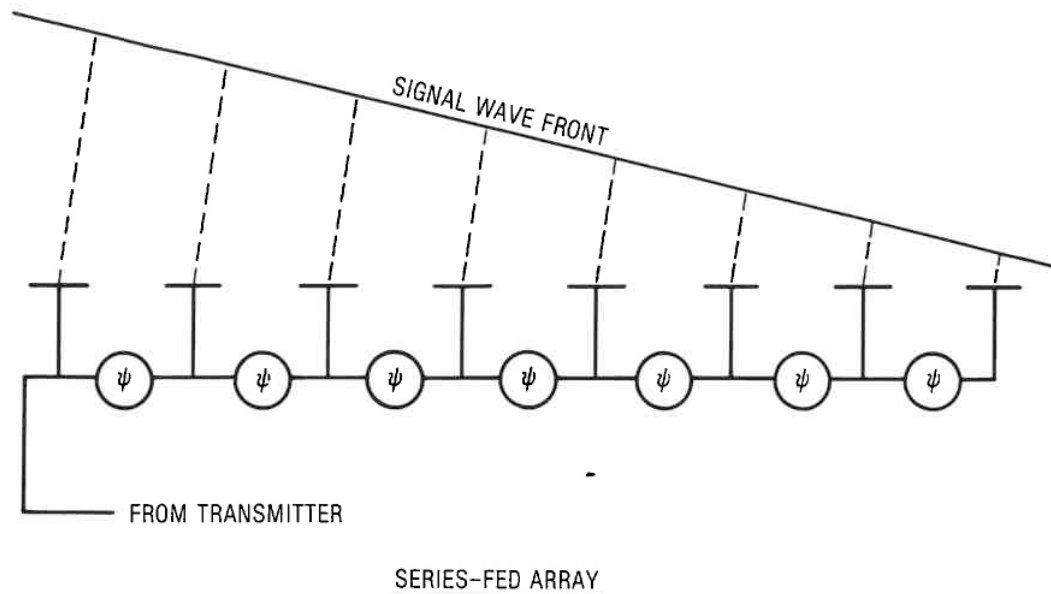
### Phased Arrays

The phased array type of antenna is used to provide electronic scanning of the radar beam primarily for faster scanning requirements. Phased arrays can be fed by several methods, including the series and parallel methods shown in **Figure 39**. Another method is to uniformly radiate a lens type of array that is made up of a mosaic of phase shifters that are computer controlled to provide the desired beam.

The **phased array** antenna consists of many individual radiating elements that are suitably spaced with respect to one another. By controlling the phase and amplitude of the signals applied to each element, desired radiation patterns can be obtained from the combined action of all elements. If all elements are spaced in a straight line, it is called a **linear array**. If the elements are arranged in two dimensions in a plane, it is called a **planar array**. If each element has a separate transmitter device, it is called an **active array**.

The active phased array is used when many low power devices are desired to power each element of the array and the power output of each is then "space combined". This antenna configuration can use either low power helix type traveling wave tubes or solid state modules. Future low frequency search radars are being designed with solid state/active phased arrays when there is no concern for very large antenna dimensions, as solid-state devices are now available with adequate power output at lower frequencies. The phased array beams are steered by changing the phase or frequency on each radiating element, requiring control and duplicity of the phase/frequency relationships of the power devices used.

Phased array antennas can produce many kinds of beam shapes, including fan and pencil beams. A single phased array may be used to scan elevation electronically, while scanning the azimuth direction mechanically. Four fixed arrays can be made to scan electronically in all directions, i.e.,



**Figure 39.** Phased array antenna feed alternatives.

a hemispherical scan. Hence, many combinations of electronic and mechanical scanning schemes are possible and are used accordingly to best fit the application.

#### **Data Rate**

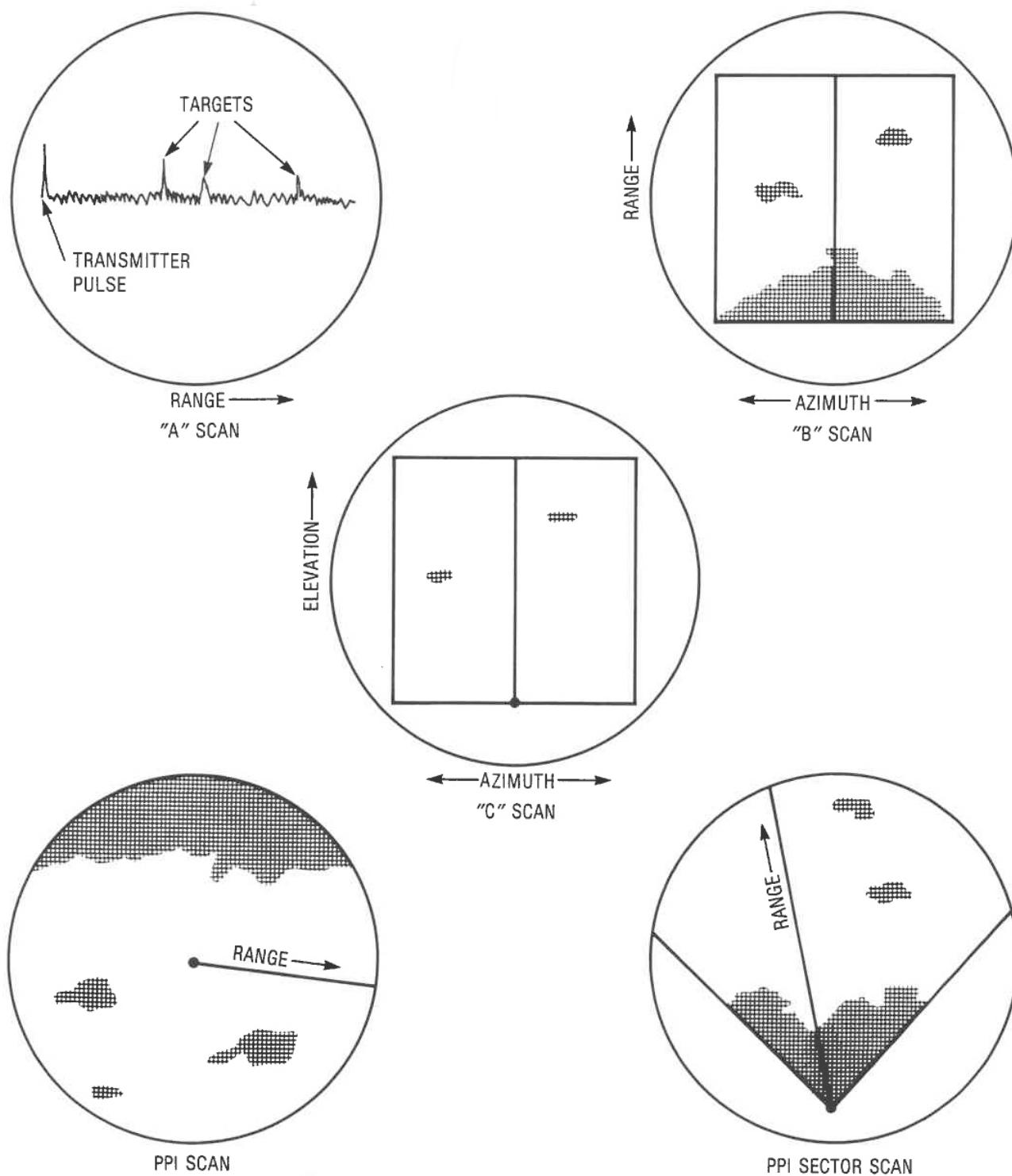
The data rate is the rate at which the radar cell sees the target. Factors such as antenna beamwidth and antenna scan rate determine the number of echoes received from a target during a particular scan. A radar with a slow scanning antenna beam will have a longer dwell time on a particular target and will

receive more pulses back during one scan. This can be important in determining the average power received from the target as well as the period of time in which a Doppler frequency can be measured. Where the number of pulses in a time measurement can be a factor in the detection of a target, the dwell time on the target must be long enough to measure the periodicity of a Doppler frequency. Electronically scanned antennas subsequently will have a limit in their scanning rate if the radar intends to process Doppler information.

## Indicators

The radar indicator displays the radar signals in a format that provides the operator with the desired information. The displays can vary as can be seen in the examples in **Figure 40**. The indicator is commonly a particular type of cathode ray tube (CRT) to which a sweeping voltage signal is applied to cause a trace to appear on the face of the CRT. This trace corresponds to one interpulse

period in time whose origin is the time when the RF pulse is transmitted from the radar antenna. When a target echo is received it is applied either to the deflecting plates of the CRT to create a picture as in the "A" display of **Figure 40** or to the grid of the CRT to amplitude modulate the light intensity of the moving trace that creates the "B", "C" or "PPI" displays.



**Figure 40.** Various radar indicator presentations.

The simplest display is the "A" type whose stationary trace only displays the range and relative amplitude of the radar echoes. These were used in many early radars for ranging purposes but are no longer used in current radars as no azimuth information is presented.

The "B" display has a moving vertical trace that moves back and forth horizontally, effectively painting a picture of range versus azimuth information. The picture is distorted at the bottom so that it presents a distorted mapping image, but it is quite satisfactory for airborne radar where zero range distortion is of little concern. The "C" type which is also used in airborne applications is essentially the same as the "B" type except the vertical dimension is in elevation instead of range.

A very common display for search radars is the "PPI" (Plan Position Indicator) display which records radar data in polar format, ideal for 360° scanning antennas. The center of the screen is range zero. A variation is the Sector PPI display used for presenting ground mapping information that is not distorted as in the "B" type.

Most cathode ray tubes are made with long persistent phosphor screens so that the trace will remain until the next trace appears at that azimuthal position. Some advanced displays will also include CRTs that can display different colors to provide contrast in radar information.

In high performance aircraft, special displays are used to give the pilot direct alpha-numerical read outs, as time does not always allow radar display interpretation in a high-speed encounter. Such information as the radar mode, a visual horizon, relative altitude of target, target velocity, target acceleration, range, etc., are all provided for immediate information requirements.

### **Radar ECCM**

In order to provide continued radar operation in an unfriendly environment, the radar must include additional equipment to provide an Electronic Counter Counter Measures (ECCM) technique capability. The unfriendly environment may include various jamming signals, both CW and pulse, at both narrow and wideband frequencies, as well as the numerous types of clutter, be it ground clutter, weather clutter or chaff (a cloud of tinfoil strips cut to desired wave lengths to give a large volume radar return).

In order to best challenge the jamming threat,

a radar will have to be configured to use techniques in the time domain, frequency domain and the spatial domain to reduce the unwanted interference, either individually or in combination.

These techniques include frequency agility operation where the transmitter frequency is programmed to the frequency of least interference. Other techniques include coherent *side* lobe cancellation (CSLC) and side lobe blanking to reduce interference from stand-off jammers and deception jammers. Techniques earlier discussed in reducing clutter, STC, etc., are also used to reduce the effects of weather, clutter and chaff problems.

The military radar designer, who must be concerned with an unfriendly environment, will incorporate into the radar the techniques of frequency, amplitude, time, velocity and antenna pattern processing in order to obtain the intended performance from the radar system.

### **Low Probability of Intercept**

One disadvantage of using a radar to detect a military target is that of transmitting a signal that can be detected by the enemy. The basic strategy is to radiate only when essential and then to radiate only enough power to achieve the desired range. As the range decreases, the radiated power is also decreased to minimize the probability of interception. This is called power management. Increasing the receiver sensitivity and the radar's ability to detect very weak targets will add to the LPI capability. Operating at higher frequencies where the propagation losses are high will also improve the LPI performance.

### **Microwave Tubes Used in Radar Systems**

Early radar systems operated at low frequencies because electron tubes were not available for operation at higher frequencies. The density-modulated triodes and tetrodes used in commercial radio and communications transmitters were the only available high-power tubes until velocity modulated microwave tubes were invented and produced.

The **Magnetron** was the first practical high-power microwave oscillator produced in large quantities and it was the principal means of providing high power microwave pulses for radar systems until microwave amplifier tubes became available. The magnetron is a crossed-field oscillator (the magnetic focusing field is perpendicular to the electron beam)

and is primarily used in non-coherent radar systems.

Magnetrons provide power at kilowatt and megawatt levels and are very efficient devices (the output power is high compared to the input power it needs to operate). They are used in many radar systems that (1) do not require coherent detection techniques, or (2) are designed for economy and limited performance. Commercial airborne weather radars, small boat radars, and terrain following radars are examples of magnetron type radars.

Magnetrons can be made to operate in coherent systems if a stable coherent signal, usually about 10 dB below the magnetron's power output, is used to "lock-up" the magnetron by injecting the signal into the magnetron. Other techniques to improve magnetron performance include priming the magnetron so that its starting time (jitter) is improved. A means of using a magnetron to provide a coherent-on-receive radar is shown in **Figure 24**.

The **Klystron** amplifier tube is probably the most reliable, stable and most economic microwave tube that can be used in a radar transmitter, if its bandwidth does not limit radar performance. The microwave tube industry is continuing to develop wider bandwidth klystrons and "smart" tuning klystrons in order to satisfy new system requirements. One advantage of a klystron is its shorter interaction length that allows permanent magnet focusing, providing the best electron optics for minimizing noise critical to systems that depend on Doppler frequency measurements. Additionally, higher average power output is achievable without having to use heavy, power consuming focusing solenoids. Even though the klystron suffers from wide bandwidth performance, its narrower bandwidth enhances the spectral purity of its output and that is sometimes a more desired radar feature than wide bandwidth performance.

To achieve wider operating bandwidth than a klystron can offer, the choice is either that of the **Traveling Wave Tube (TWT)** or a **Crossed Field Amplifier (CFA)**.

There are several types of traveling wave tubes, made according to the power output and frequency bandwidth that is needed. The **helix traveling wave tube** can provide an octave or more of instantaneous frequency bandwidth at

power levels up to several kilowatts. These TWTs are ideal for achieving wideband frequency agility for target enhancement and ECCM purposes and for providing wideband missile seeker performance. The helix TWT is also well suited for active phased array applications and for driver amplifier use when higher power TWTs are needed as final amplifiers. Higher power TWTs that provide more power output, but less bandwidth, are called **coupled cavity TWTs** and can provide power outputs in the 100s of kilowatts but at bandwidths usually less than 10 percent of the operating frequency.

As the trend in airborne radars has been toward combining many radar functions into one radar system, the transmitter becomes more complex in its requirements to change the radar waveform in order to suit the mode of operation. The total radar requirements call for wider operating frequency range, variable pulse recurrence frequency, variable pulse widths, coherency, pulse coding, power programming, etc. The modern airborne multi-mode radar systems generally use a gridded Coupled-Cavity Traveling Wave Tube (CCTWT) as the final amplifier in the transmitter, as it is the best device to provide the frequency bandwidth as well as the low noise attributes of a linear beam tube. The gridded electron beam feature allows modulating the tube at high pulse recurrence frequencies with low voltage modulating pulses, reducing considerably the modulator power while being able to achieve better pulse shaping of the signal.

Some search radars used hybrid tubes called **Twystrons**, a combination of klystron and traveling wave tube technology. These tubes are designed for power outputs in the megawatts and provide bandwidths of the order of 10 percent. A new type of high-power klystron amplifier, the **Extended Interaction Klystron (EIK)**, is now being produced for replacement of Twystrons in new and existing systems. The EIK provides improved performance in bandwidth and promises to be a more reliable and less expensive power amplifier for wideband radar applications.

From the magnetron, a crossed field oscillator, the **Crossed Field Amplifier (CFA)** tubes evolved which are used in a number of radar systems. The CFA has the advantage of low operating voltage, good bandwidth and very good efficiency. It has suffered in gain (about 10-13 dB) compared to the

40-60 dB gain capability of the linear beam tubes but recent developments in CPA technology appear to increase CFA gain to the 20 to 25 dB range. The CFA also can be designed as a tube with little transmission loss when it is not turned on, so that it can be a power booster as desired for system power management.

Another family of microwave tubes is called **Gyrotrons**. These are tubes that provide much higher power than linear beam tubes at millimeter-wave frequencies. Most gyrotrons made to date have been designed for energy-producing machines. However, there is continuing interest in making gyrotron amplifiers if the radar community requires very high-power output levels at millimeter-wave frequencies, such as a megawatt at 100 GHz.

### **Radar System Bandwidth**

The amount of operating bandwidth of a radar system is determined by one or more of the following performance requirements:

1. Narrow-band frequency agility to enhance detection and minimize target scintillation.
2. Narrow-to-wide band frequency bandwidth to allow modulation of the signal for pulse compression purposes.
3. Narrow-to-wide band frequency agility to handle multiple target tracking.
4. Wide band frequency agility to avoid hostile jamming signals.
5. Frequency control to avoid friendly interference.

It should be noted that when processing Doppler frequency information, the operating carrier frequency is not usually varied, as Doppler frequency shifts will vary linearly with the operating carrier frequency, thereby confusing the Doppler measurement.

The bandwidth of radar systems is determined by (1) what is actually needed to achieve the radar's objectives, (2) the ECM threat (real or anticipated), (3) frequency-limiting components of the system (such as a high velocity missile's radome frequency characteristics), and (4) the customer's desires. Generally, the wider the bandwidth of the system, the more expensive the system becomes, as components become more complex and expensive.

### **Radar Techniques**

Radar system manufacturers, in their attempt to make their products as salable as possible, try to incorporate as many of the state-of-the-art techniques as are economically feasible. Some of the more popular techniques now being used include:

1. Short pulse transmission
2. Digital data processing
3. Pulse compression
4. Pulse coding
5. Phase coherency (pulse-to-pulse phase relationship)
6. Coherency-on-receive (inter-pulse phase relationship)
7. MTI (Moving Target Indication), AMTI (airborne)
8. Monopulse tracking
9. Frequency agility
10. Polarization agility
11. Electronic scanning (phased arrays)
12. Synthetic aperture radars, ISAR (inverted SAR)
13. Doppler beam sharpening
14. PRF agility
15. ECCM
16. Low probability of intercept

The above items become some of the selling features of radar system manufacturers in their selling efforts to their customers. Again, the amount and quality of information that a radar system can extract from an operating environment is a measure of that system. Other factors include system acquisition cost, maintenance costs, efficiency of operation, and reliability.

### **Future Trends in Radar**

New technologies will undoubtedly alter the capability of radar in the future to detect and process complex information faster and more efficiently. Radars will evolve into even more multi-mode systems than now exist. The digital signal processor art will improve significantly with VLSI (very large-scale integrated circuit technology) becoming a reality in practical system hardware. The improvements expected in data storage will further improve the real time capabilities in synthetic aperture radar and ISAR techniques. The latter, combined with VLSI capability will help to

make on-board radar target discrimination more likely for future weapon deliveries.

The advances in solid state devices will push the solid-state transmitter art into the higher frequencies. One might expect a not-too-far off generation of advanced multi-mode airborne radars to be all solid state at X-band frequencies with active array antenna configurations. Antennas will become more conformal to the aircraft's geometry appearing not only in nose areas but in leading edges of wings and in various fuselage areas.

The continuing interest to develop more successful bistatic radars is likely to produce some deployable equipment in the future that will enhance military radar use. The advances in data processing should be of considerable assistance in solving the present complex problems now plaguing bistatic radar system designers.

The advancements in new microwave and millimeter-wave tube technologies will also provide the industry with devices to challenge new radar techniques and radar performance.

While radar technology has principally evolved from military requirements, new developments in detecting weather, wind shear, clear air turbulence, "microbursts", etc., will contribute significantly to the increased safety of the public, both on the ground and in the air.

### Radar Relationships

#### 1. Radar Equation

$$\frac{S}{N} = \frac{PG^2\lambda^2\sigma}{(4\pi)^3R^4NF kTB L}$$

#### 2. S/N at Range, R

$$\frac{S}{N} = \left(\frac{R_0}{R}\right)^4$$

$R_0$  is the range at  $S/N = 1$

#### 3. Antenna Gain

$$G = \frac{4\pi A}{\lambda^2}$$

A = Aperture Area

#### 4. Antenna Beamwidth, Half Power, Circular Linear Array

$$\Theta \cong \frac{57\lambda}{d} \text{ degrees}$$

d = diameter

#### 5. Duty Cycle of Pulsed Radar

$$D_u = \text{Pulse Width} \times \text{PRF}$$

#### 6. Average Power = Peak Power $\times$ Duty Cycle

#### 7. Range

$$R = \frac{T_r c}{2}$$

$T_r$  = time (round trip)

c = velocity of propagation

#### 8. Unambiguous Range, Single PRF

$$R_u = \frac{c}{2 \text{ PRF}}$$

PRF = Pulse Recurrence Frequency

#### 9. Unambiguous Range, Multiple PRF

$$R_u = \frac{c}{2(\text{PRF}_1 - \text{PRF}_2)}$$

#### 10. Interpulse Period

$$T = \frac{1}{\text{PRF}} - \tau$$

$\tau$  = Pulse Width

#### 11. Velocity of Propagation (velocity of light), c

c = 2.997925  $\times 10^8$  meters/second

c = 186,282 statute miles/second

c = 161,875 nautical miles/second

c = 984 feet/microsecond

Time to travel one (1) nautical mile, round trip,

$$= 12.34 \times 10^{-6} \text{ seconds.}$$

#### 12. Doppler Frequency

$$F_d = \frac{2 V_r F_o}{c}$$

$V_r$  = Relative Velocity

$F_o$  = Transmitted Frequency

#### 13. Pulse Compression Ratio

Ratio =  $\Delta F \times$  Pulse Width

$$\text{Compressed Pulse Length} = \frac{1}{\Delta F}$$

Compressed Pulse Amplitude =  $A\sqrt{\Delta F \tau}$

A is transmitted peak power of pulse.



14. Wavelength, Frequency

$$\lambda = \frac{c}{F}$$

$$F = \frac{30}{\lambda(\text{cm})} \text{ GHz}$$

$$\lambda = \frac{30}{F(\text{GHz})} \text{ CM}$$

c = Velocity of Propagation

F = Frequency

λ = wavelength

15. Receiver Bandwidth

(a) Low PRF Radars

$$BW = \frac{1}{\tau}$$

(b) High PRF Radars (Pulse Doppler)

$$BW \text{ (each filter)} = \frac{B}{T_i^2}$$

B = Antenna Beamwidth,

T<sub>i</sub> = Target Illumination Time

16. Noise Figure of an Amplifier

$$\overline{NF} = \frac{S/N \text{ In}}{S/N \text{ Out}}$$

17. Overall Noise Figure of a Series of Amplifiers, 1, 2, and 3.

$$\overline{NF} = \overline{NF}_1 + \frac{\overline{NF}_2 - 1}{G_1} + \frac{\overline{NF}_3 - 1}{G_1 G_2}$$

G = Amplifier Gain

18. Thermal Noise Level

$$kTB = -204 \text{ dBW/Hertz}$$

$$= -114 \text{ dBm/MHz}$$

19. Boltzman's constant

$$k = 1.38 \times 10^{-23} \text{ joule/degree}$$

- Radar Bands*	
BAND	FREQUENCIES
VHF	138-144 MHz
	216-225 MHz
UHF	420-450 MHz
	890-942 MHz
L	1215-1400 MHz
S	2300-2500 MHz
	2700-3700 MHz
C	5250-5925 MHz
X	8500-10,680 MHz
Ku	13.4-14.0 GHz
	15.7-17.7 GHz
K	24.05-24.25 GHz
Ka	33.4-36.0 GHz

\*Bands assigned by International Telecommunications Union

### Bibliography

1. Introduction to Radar Systems, Skolnik, M.L., McGraw-Hill, 1980.
2. Radar Handbook, Skolnik, M.L. (ed.), McGraw-Hill, 1970.
3. Radars, Barton, D.K. (ed.), Artech House, 1974-1979.
4. Radar Detection and Tracking Systems, Hovenessian, S.A., Artech House, 1973.
5. Radar Systems Analysis, Barton, D.K., Artech House, 1976.
6. Radar Design Principles, Nathanson, F.E., McGraw-Hill, 1969.
7. Radar System Engineering, Ridenour, L.N., McGraw-Hill, 1947.